



JOHN POMP

INFINITY CHANDELIER



INFINITY CHANDELIER

MODEL NO: JPSINCH-01

30-35 pieces of hand-blown, sculpted glass crystal within a handcrafted metal frame in two-way mirrored enclosure

AS SHOWN (IN PHOTO)

Glass - clear
Metal - light oil rubbed blackened steel

DIMENSIONS

48"W x 16"H x 16"D - drop lengths customizable

AVAILABLE FINISHES

See glass color and metal finish list

ELECTRICAL

6w incandescent bulb per socket included
2w LED alternative available

ADDITIONAL NOTES

Lead time is 10-12 weeks, additional 2-3 weeks for premium finishes.
Includes studio mark and craftsman signature. UL listing not available.

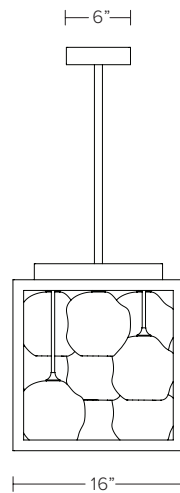
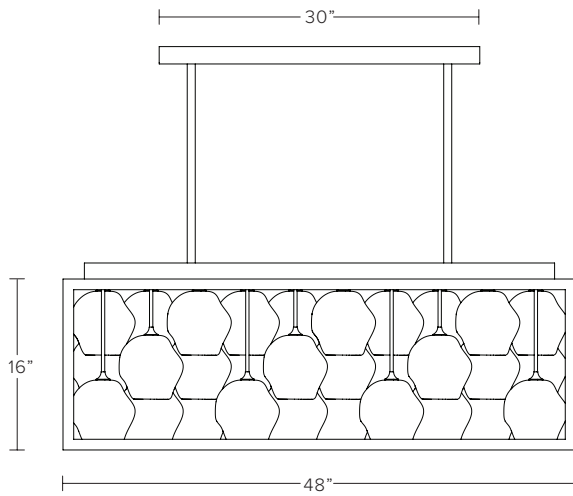



JOHN POMP

ROCK EDGE CHANDELIER



ROCK EDGE CHANDELIER

MODEL NO: JPSRECH-01

Hand-cast, sculpted glass crystal pieces suspended from a two-tiered circular metal frame with mounting canopy and bottom mounted acrylic diffuser

AS SHOWN (IN PHOTO)

48" overall diameter x 12"H
 Glass - clear with iridescence
 Glass Style - rock edge
 Metal - satin nickel
 Diffuser - rock edge

DIMENSIONS

Available in four sizes:

30" overall diameter x 12"H; approx. 32 pieces of glass crystal
 36" overall diameter x 12"H; approx. 40 pieces of glass crystal
 42" overall diameter x 12"H; approx. 46 pieces of glass crystal
 48" overall diameter x 12"H; approx. 54 pieces of glass crystal

Glass dimensions may vary slightly due to sculpted process

AVAILABLE FINISHES

Glass - clear or clear with iridescence
 Glass style - rock edge glass or ostrea glass
 Metal - see metal finish list
 Diffuser style - rock edge diffuser or ostrea diffuser

ELECTRICAL

Incandescent bulb included per socket (5)
 30" od / 36" od - 60w
 42" od / 48" od - 75w

LED alternative available
 30" od / 36" od - 2w
 42" od / 48" od - 4w

ADDITIONAL NOTES

Lead time is 10-12 weeks, additional 2-3 weeks for premium finishes.

Includes studio mark. UL listed.

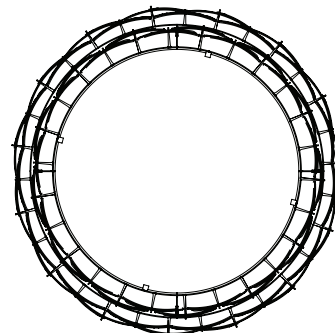
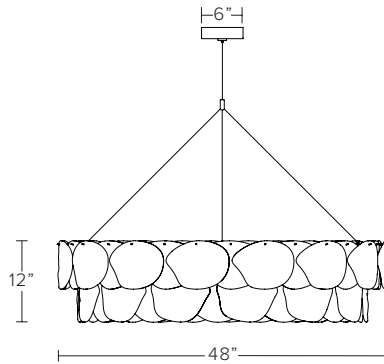



JOHN POMP

OSTREA CHANDELIER



OSTREA CHANDELIER

MODEL NO: JPSOCH-01

Hand-cast, sculpted glass crystal pieces suspended from a three-tiered rectangular metal frame with four point aircraft cable suspension, mounting canopy, and bottom mounted acrylic diffuser

AS SHOWN (IN PHOTO)

68"L x 25.5"W x 15"H

Glass - clear

Metal - satin nickel

Diffuser - ostrea

DIMENSIONS

Available in three sizes:

41"L x 25.5"W x 15"H; approx. 58 pieces of glass crystal

54"L x 25.5"W x 15"H; approx. 76 pieces of glass crystal

68"L x 25.5"W x 15"H; approx. 94 pieces of glass crystal

Glass dimensions may vary slightly due to sculpted process

Metal - see metal finish list

Diffuser style - ostrea diffuser or rock edge diffuser

ELECTRICAL

60w incandescent bulb per socket included

5w LED alternative available

41"L - 3 bulbs / 54"L - 4 bulbs / 68"L - 5 bulbs

ADDITIONAL NOTES

Lead time is 10-12 weeks, additional 2-3 weeks for premium finishes.

Includes studio mark . UL listed.

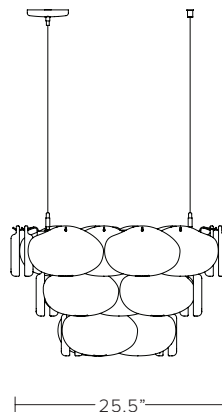
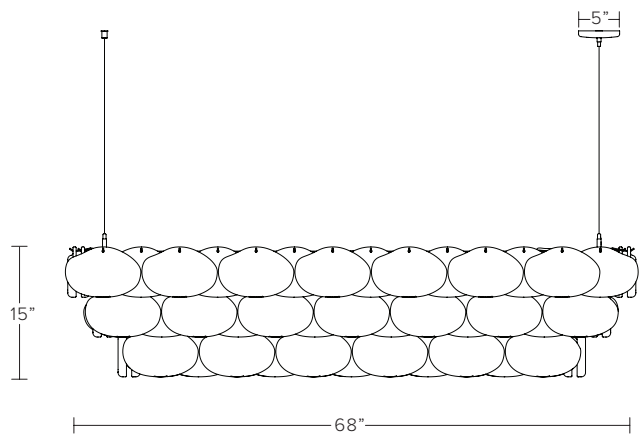



JOHN POMP

JULES CHANDELIER



JULES CHANDELIER

MODEL NO: JPSJCH-01

Hand-cast, sculpted glass crystal pieces suspended from a three-tiered elliptical metal frame with four point aircraft cable suspension, mounting canopy, and bottom mounted acrylic diffuser

AS SHOWN (IN PHOTO)

77"L x 31.5"W x 20.5"H

Glass - clear

Metal - satin nickel

DIMENSIONS

Available in three sizes:

57"L x 31.5"W x 20.5"H; approx. 66 pieces of glass crystal

67"L x 31.5"W x 20.5"H; approx. 78 pieces of glass crystal

77"L x 31.5"W x 20.5"H; approx. 90 pieces of glass crystal

Glass dimensions may vary slightly due to sculpted process

AVAILABLE FINISHES

Glass – clear

Metal – see metal finish list

ELECTRICAL

60w incandescent bulb per socket included

5w LED alternative available

57"L - 4 bulbs / 67"L - 5 bulbs / 77"L - 6 bulbs

ADDITIONAL NOTES

Lead time is 10-12 weeks, additional 2-3 weeks for premium finishes.

Includes studio mark. UL listed.

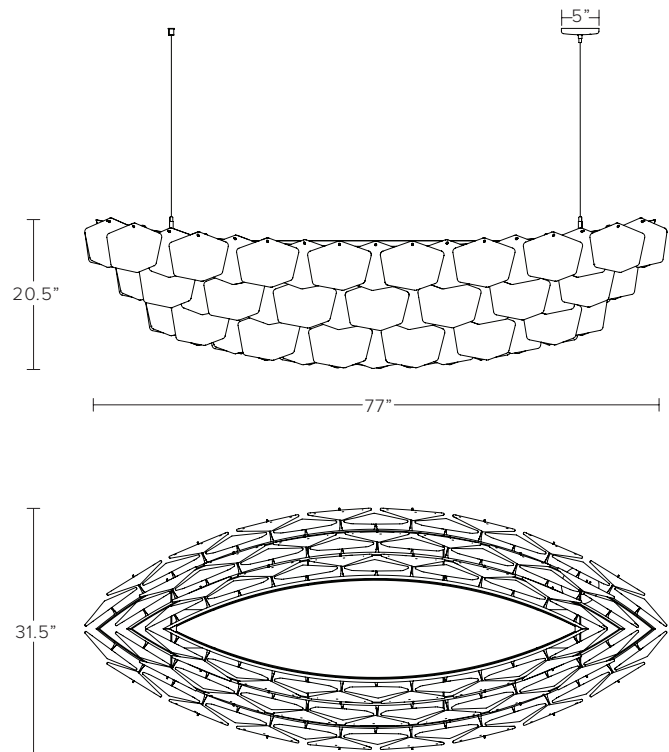

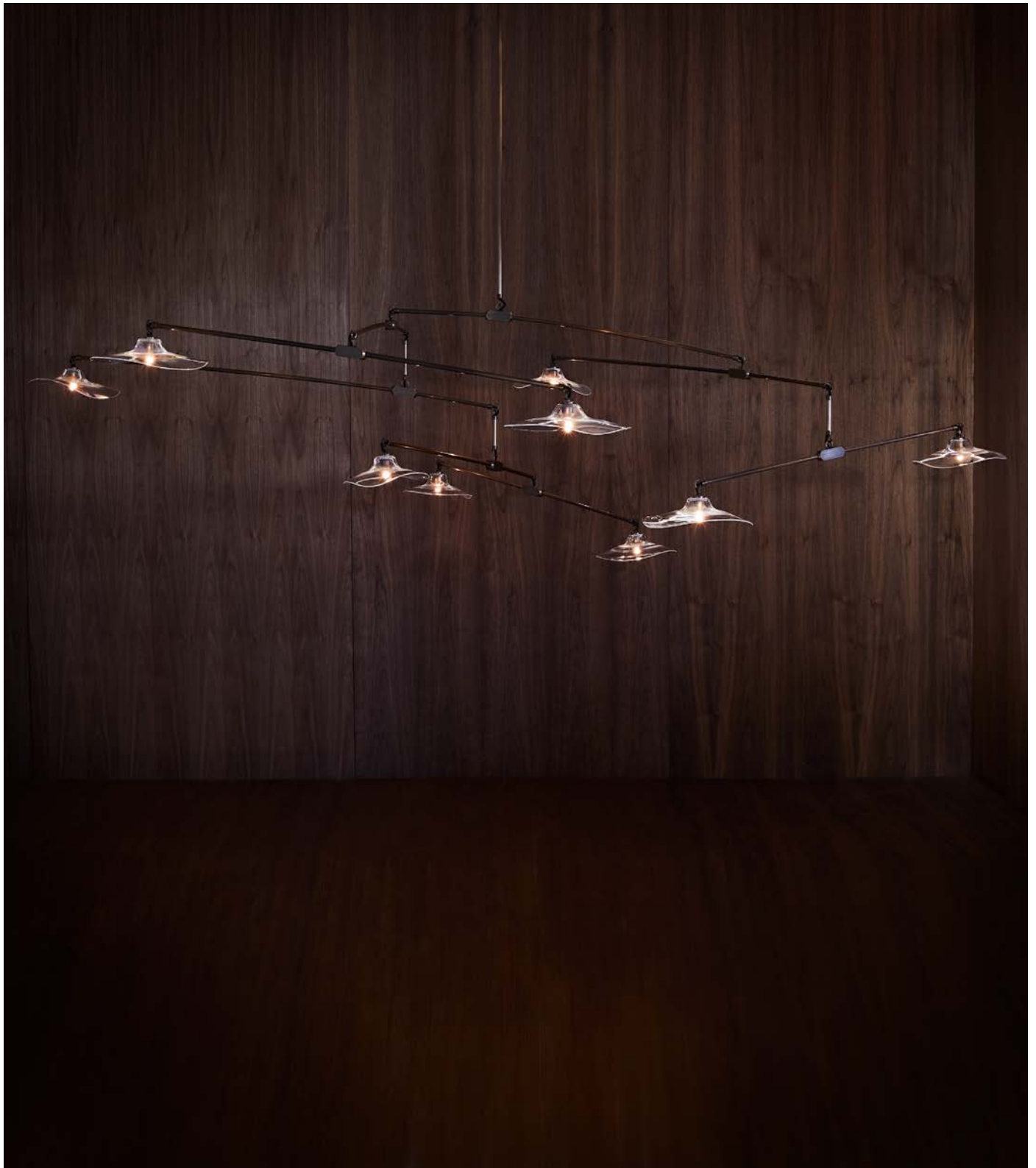

©2020 JOHN POMP STUDIOS (U.S. PATENT NO. D862,767)



JOHN POMP

CALLA MOBILE

CALLA MOBILE

MODEL NO JPSCM-01

Hand-blown, sculpted glass crystal pieces balanced from solid brass mobile

AS SHOWN (IN PHOTO)

9 glass pieces - approx. dimensions 120"L x 84"W
Glass - clear with iridescence
Metal - oxidized brass

DIMENSIONS

Available in four sizes:

3 glass pieces - approx. dimensions 60"L x 36"W
5 glass pieces - approx. dimensions 84"L x 48"W
7 glass pieces - approx. dimensions 108"L x 60"W
9 glass pieces - approx. dimensions 120"L x 84"W

Glass - 12"W x 9"D x 3"H

Glass dimensions may vary slightly due to sculpted process

ELECTRICAL

6w incandescent bulb per socket included

AVAILABLE FINISHES

Glass - see glass finish list
Metal - satin brass (standard), oxidized brass, satin nickel, oil rubbed blackened steel or light oil rubbed blackened steel

ADDITIONAL NOTES

Lead time is 10-12 weeks, additional 2-3 weeks for premium glass colors.

Custom piece can be commissioned by artist upon request.

As per design intent, fixture may balance at angles different from what is shown and arms will reposition slightly if contact is made.

All dimensions listed are approximate and should be considered +/- 6".

Includes studio mark. UL listed.



3 PIECE, 60"L X 36"W

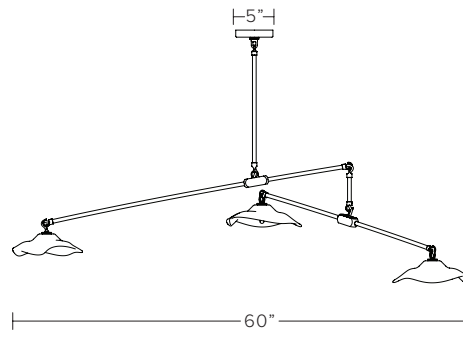

5 PIECE, 84"L X 48"W

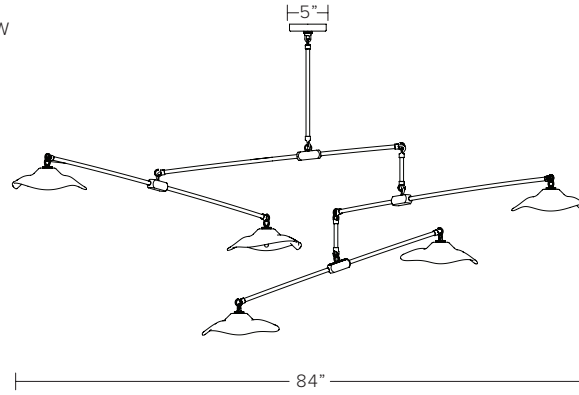

7 PIECE, 108"L X 60"W

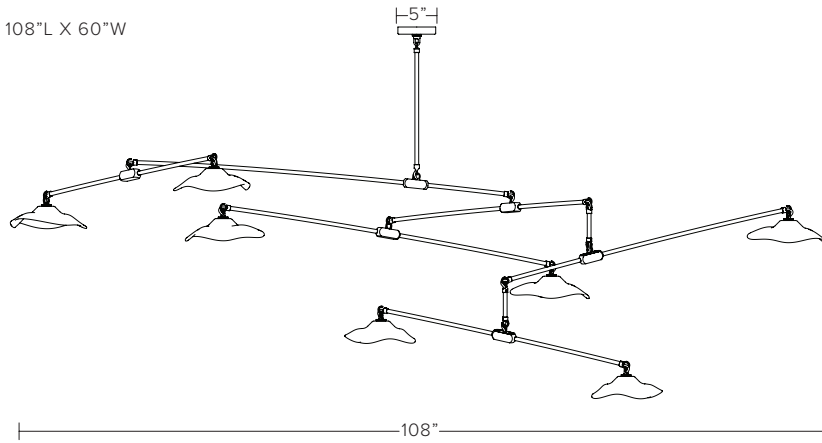

9 PIECE, 120"L X 84"W

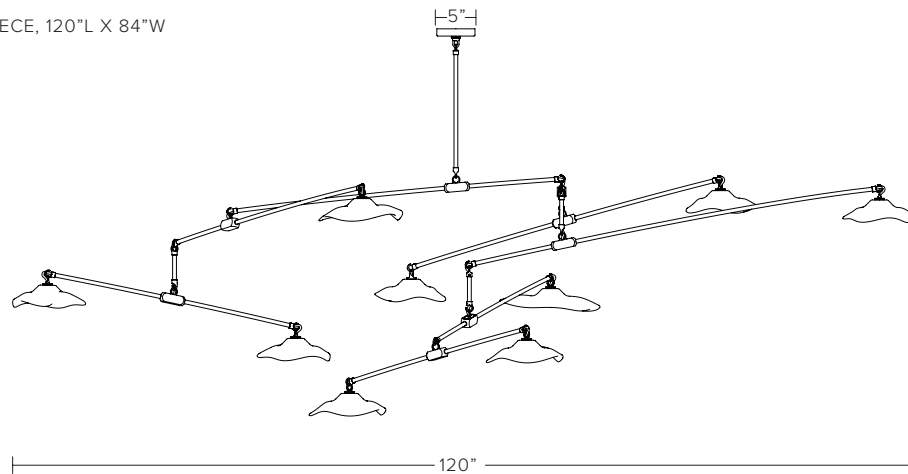





JOHN POMP

CALLA CHANDELIER

CALLA CHANDELIER

MODEL NO JPSCCH-01

Hand-blown, sculpted glass crystal pieces suspended from an adjustable solid brass armature.

AS SHOWN (IN PHOTO)

6 glass pieces, 3 tiers - approx. dimensions 70"L x 52"W* x 12"H
Glass - smoke with iridescence
Metal - oil rubbed blackened steel

DIMENSIONS

Available in three sizes:

4 glass pieces, 2 tiers - approx. dimensions 60"L x 48"W* x 9"H
6 glass pieces, 3 tiers - approx. dimensions 70"L x 52"W* x 12"H
8 glass pieces, 4 tiers - approx. dimensions 80"L x 66"W* x 14.5"H

**Arms can be rotated around center, allowing the fixture to be displayed in various arrangements, which will affect the overall width.*

Glass - large approx. 12"W x 9"D x 3"H
small approx. 9"W x 7"D x 3"H

Glass dimensions may vary slightly due to sculpted process

ELECTRICAL

6w incandescent bulb per socket included

AVAILABLE FINISHES

Glass - see glass finish list

Metal - satin brass (standard), oxidized brass, satin nickel, oil rubbed blackened steel or light oil rubbed blackened steel

ADDITIONAL NOTES

Lead time is 10-12 weeks, additional 2-3 weeks for premium glass colors.

Includes studio mark. UL listed.



4 PIECE, 2 TIER 60"L X 48"W* X 9"H

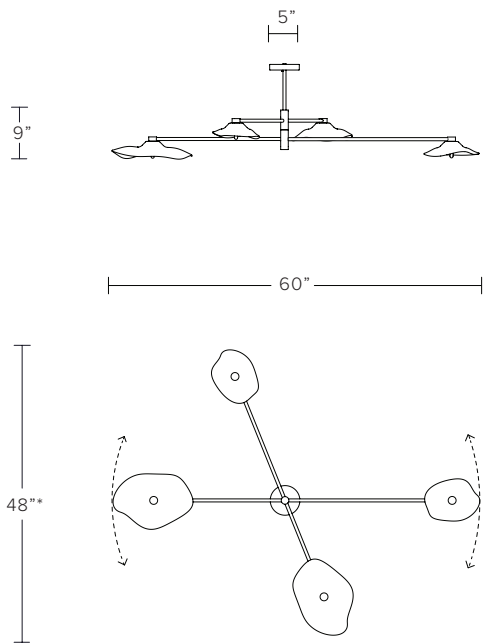

6 PIECE, 3 TIER 70"L X 52"W* X 12"H

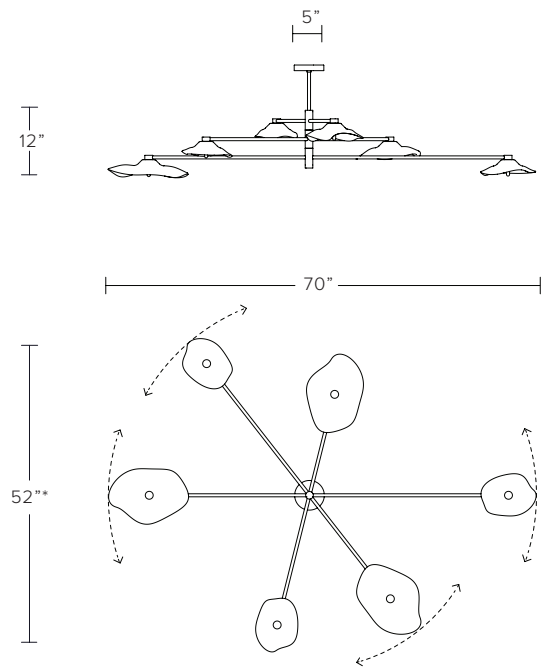

8 PIECE, 4 TIER 80"L X 66"W* X 14.5"H

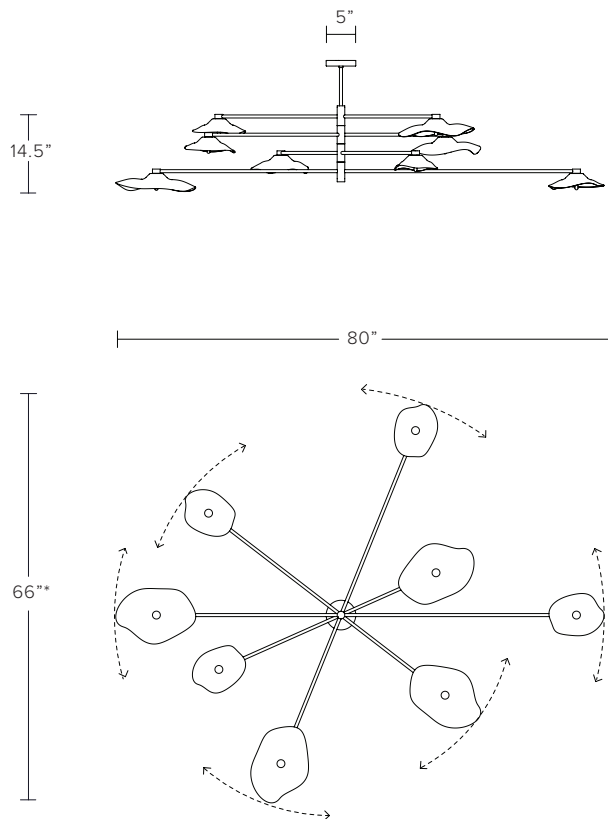





JOHN POMP

CALLA PENDANT



CALLA PENDANT

MODEL NO: JPSCPEL-01

MODEL NO: JPSCPES-01

Hand-blown, sculpted glass crystal pieces suspended from rigid stems.

AS SHOWN (IN PHOTO)

Glass - clear with iridescence
Metal - satin brass

DIMENSIONS

Available in 2 sizes:

Large - 12"W x 9"D x 3"H

Small - 9"W x 7"D x 3"H

Glass dimensions may vary slightly due to sculpted process

CONFIGURATIONS

5" diameter canopy provided per pendant with custom canopies and stem lengths available - pricing upon request

Various canopy and pendant configurations available - see custom configuration guides for more information

AVAILABLE FINISHES

Glass - see glass finish list

Metal - satin brass (standard), oxidized brass, satin nickel, oil rubbed blackened steel, light oil rubbed blackened steel

ELECTRICAL

6w incandescent bulb per socket included

ADDITIONAL NOTES

Lead time is 10-12 weeks, additional 2-3 weeks for premium glass colors.

Includes studio mark. UL listed.

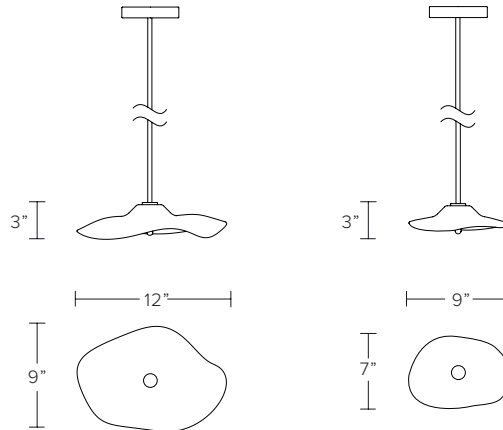



JOHN POMP

TIDAL CHANDELIER

TIDAL CHANDELIER

MODEL NO JPSTCH-01

Hand-cast, sculpted glass crystal pieces suspended from curved metal stems flowing from a hand forged, organic mounting canopy

AS SHOWN (IN PHOTO)

5 Piece "Low" - approx. dimensions 104"L x 70"W x 34"-36"H*
Glass - clear crystal
Metal - brushed brass

DIMENSIONS

Available in four sizes:

3 Piece "High" - 3 glass pieces
approx. dimensions 72"L x 58"W x 22"-24"H*

3 Piece "Low" - 3 glass pieces
approx. dimensions 72"L x 58"W x 34"-36"H*

5 Piece "High" - 5 glass pieces
approx. dimensions 104"L x 70"W x 22"-24"H*

5 Piece "Low" - 5 glass pieces
approx. dimensions 104"L x 70"W x 34"-36"H*

Glass - large approx. 9.5" x 8"
small approx. 8.5" x 7"

Glass dimensions may vary slightly due to sculpted process

**Due to the sculpted process of the glass, the OAD will fall within the 2" range specified.*

ELECTRICAL

25w incandescent bulb per socket included

4w LED alternative available

AVAILABLE FINISHES

Glass - clear crystal, soft etched clear crystal

Hand-etched glass has naturally variegated surface

Metal - oil rubbed blackened steel, brushed silver, brushed brass

ADDITIONAL NOTES

Lead time is 8-10 weeks, additional 2-3 weeks for premium finishes.

Includes studio mark. UL listed.



3 PIECE "HIGH", 72"L X 58"W X 22"-24"H*

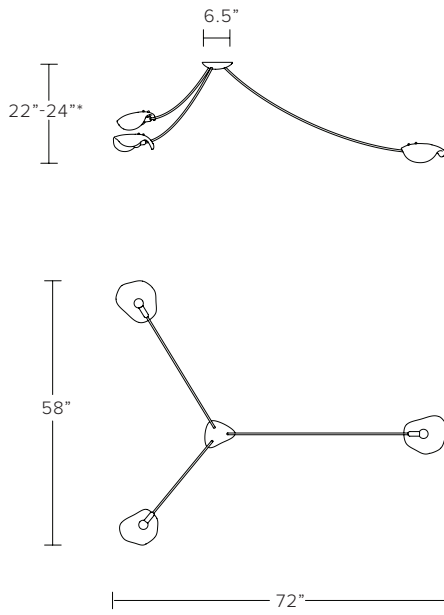

3 PIECE "LOW", 72"L X 58"W X 34"-36"H*

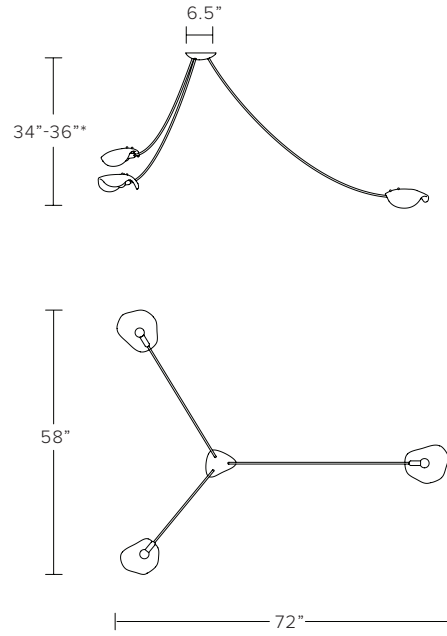

5 PIECE "HIGH", 104"L x 70"W x 22"-24"H*

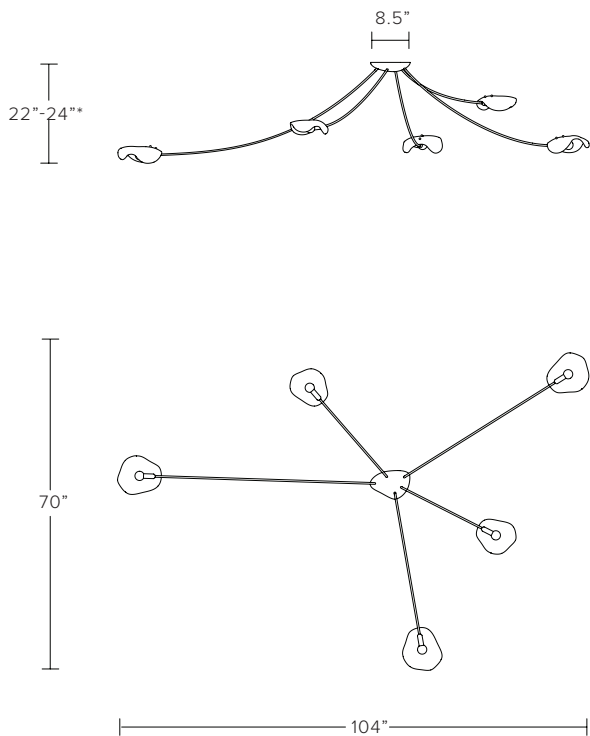

5 PIECE "LOW", 104"L x 70"W x 34"-36"H*

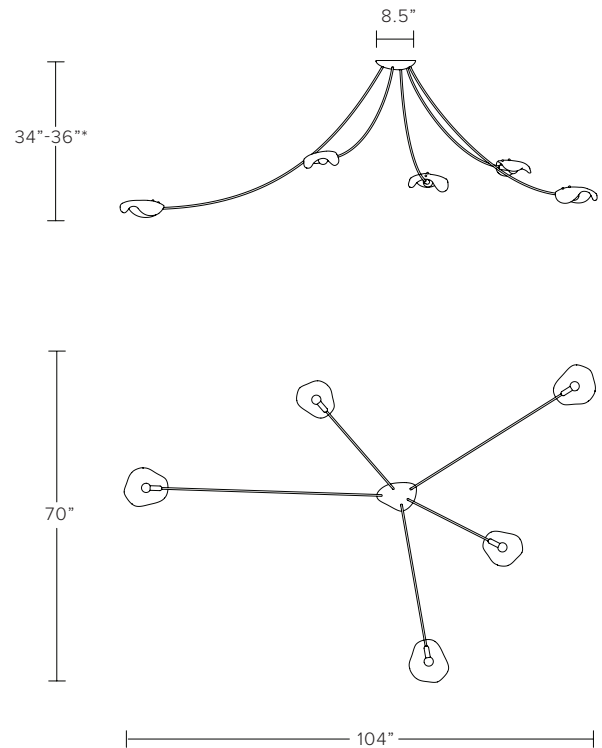

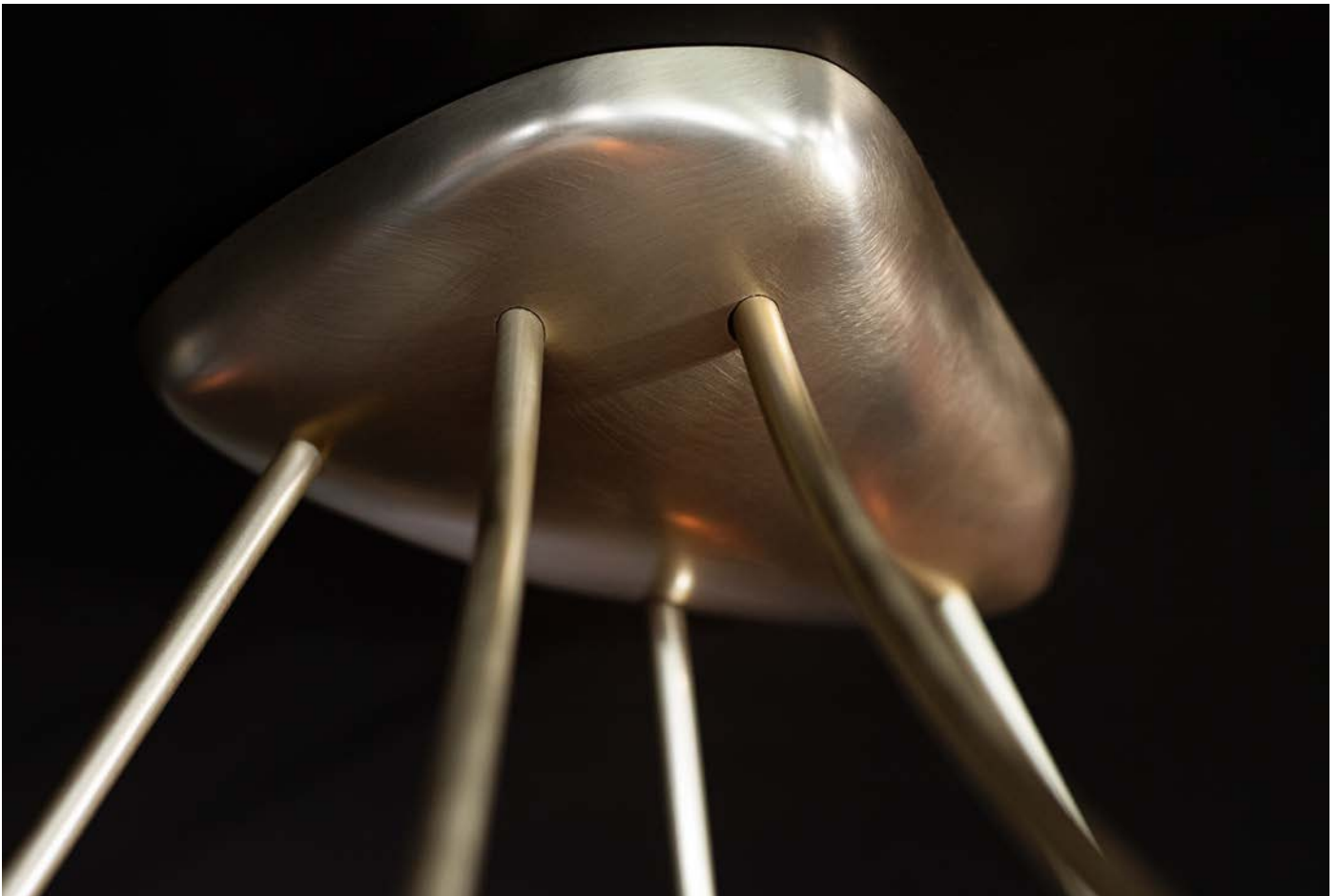



JOHN POMP

BUDDING CHANDELIER



BUDDING CHANDELIER

MODEL NO: JPSBCH-01

Hand-blown, organically sculpted glass crystal buds suspended from crescent-armed chandelier

AS SHOWN (IN PHOTO)

10 glass pieces - approx. dimensions 22" W x 47" H
 Glass - soft etched crystal clear
 Metal - satin brass

DIMENSIONS

Available in three sizes:

4 glass pieces - approx. dimensions 17" W x 25" H
 7 glass pieces - approx. dimensions 22" W x 41" H
 10 glass pieces - approx. dimensions 22" W x 47" H

Glass - approx. 5"x 7"

Glass dimensions may vary slightly due to sculpted process

AVAILABLE FINISHES

Glass - soft etched crystal clear (standard), soft etched quartz (standard), soft etched garnet, soft etched emerald

Hand-etched glass has naturally variegated surface

Metal - satin brass (standard), satin silver, satin copper, light oil rubbed blackened steel, oil rubbed blackened steel

ELECTRICAL

25w incandescent bulb per socket included

4w LED alternative available



ADDITIONAL NOTES

Lead time is 8-10 weeks, additional 2-3 weeks for premium finishes.

Includes studio mark. UL listed.

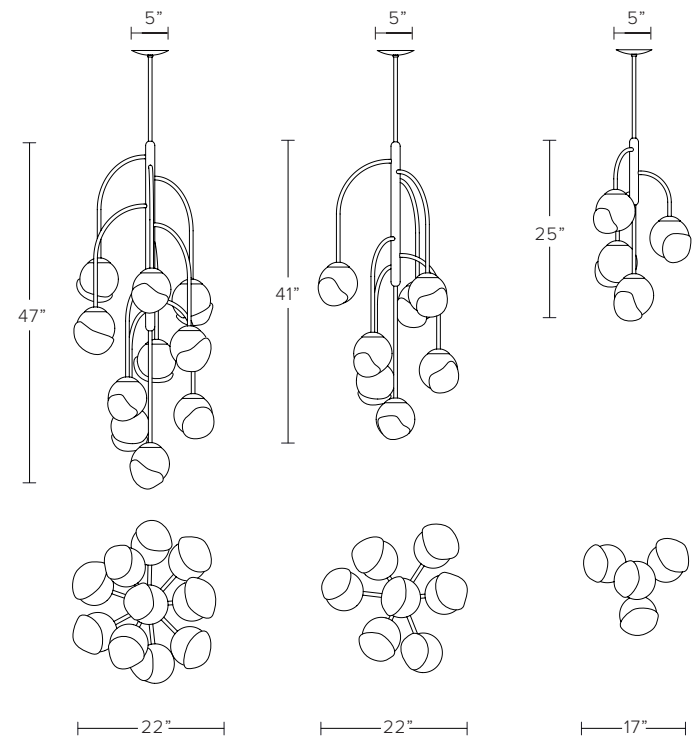



JOHN POMP

MOON ORCHID - CREST



MOON ORCHID - CREST

MODEL NO JPSMOCR-01

Hand-blown, sculpted glass crystal pieces suspended from crescent arms sprouting from turned sphere

AS SHOWN (IN PHOTO)

4 glass pieces, 2 arms - approx. dimensions 90"L x 9"W x 12.5"H
Glass - soft etched quartz and soft etched garnet
Metal - satin brass

DIMENSIONS

Available in three sizes:

4 glass pieces, 2 arms - approx. dimensions 90"L x 9"W x 12.5"H
6 glass pieces, 4 arms - approx. dimensions 90"L x 58"W x 12.5"H
8 glass pieces, 6 arms - approx. dimensions 90"L x 58"W x 12.5"H

Glass - large approx. 9" x 5"
small approx. 6" x 4"

Glass dimensions may vary slightly due to sculpted process

AVAILABLE FINISHES

Glass - soft etched crystal clear (standard), soft etched quartz (standard), soft etched garnet, soft etched emerald

Hand-etched glass has naturally variegated surface

Metal - satin brass (standard), satin silver, satin copper, light oil rubbed blackened steel, oil rubbed blackened steel

ELECTRICAL

25w incandescent bulb per socket included

4w LED alternative available

ADDITIONAL NOTES

Lead time is 8-10 weeks, additional 2-3 weeks for premium finishes.

Includes studio mark. UL listed.



4 PIECE, 2 ARM, 90"L X 9"W X 12.5"H

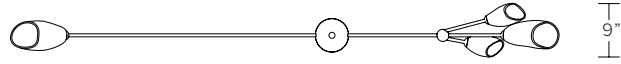
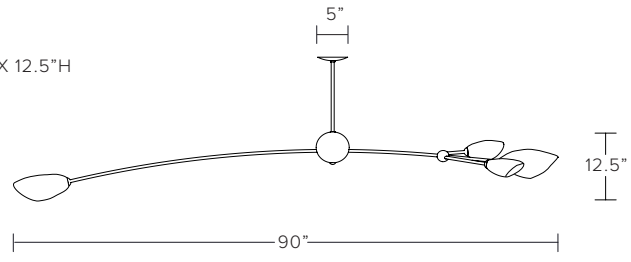

6 PIECE, 4 ARM, 90"L X 58"W X 12.5"H

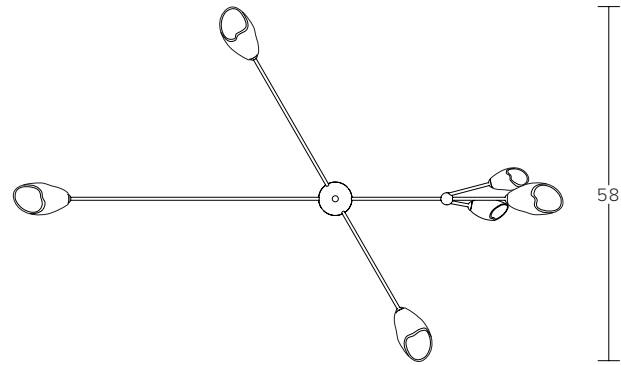
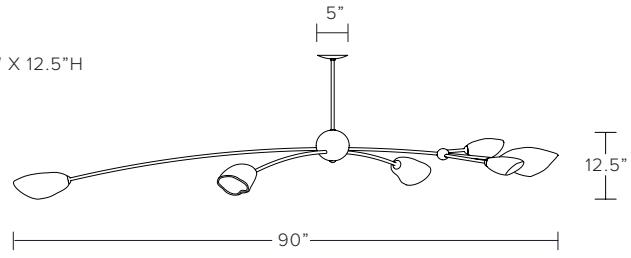

8 PIECE, 6 ARM, 90"L X 58"W X 12.5"H

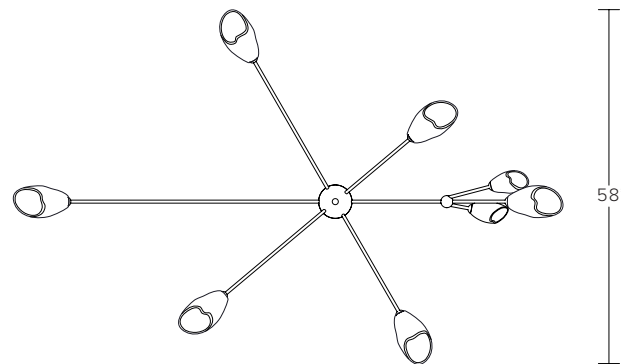
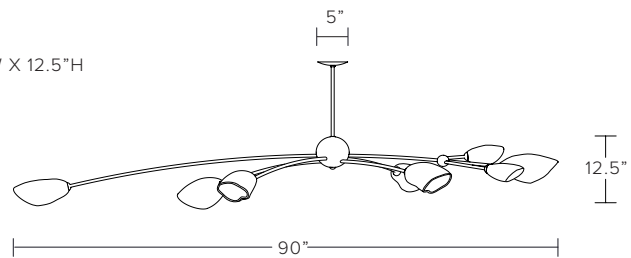



JOHN POMP

MOON ORCHID - CASCADING



MOON ORCHID - CASCADING

MODEL NO: JPSMOCA-01

Hand-blown, sculpted glass crystal pendants with solid woven metal cordage cascading from domed mounting canopy

AS SHOWN (IN PHOTO)

9 glass pieces - approx. overall dimensions 12" W x 50"H
 Glass - soft etched crystal clear
 Metal - satin brass

DIMENSIONS

Available in four sizes:

3 glass pieces - approx. overall dimensions 12" W x 20"H
 5 glass pieces - approx. overall dimensions 12" W x 30"H
 7 glass pieces - approx. overall dimensions 12" W x 40"H
 9 glass pieces - approx. overall dimensions 12" W x 50"H

Glass - approx. 9" x 5"

Glass dimensions may vary slightly due to sculpted process

AVAILABLE FINISHES

Glass - soft etched crystal clear (standard), soft etched quartz (standard), soft etched garnet, soft etched emerald

Hand-etched glass has naturally variegated surface

Metal - satin brass (standard), satin silver, satin copper, light oil rubbed blackened steel, oil rubbed blackened steel

ELECTRICAL

25w incandescent bulb per socket included

4w LED alternative available



ADDITIONAL NOTES

Lead time is 8-10 weeks, additional 2-3 weeks for premium finishes.

Includes studio mark. UL listed.

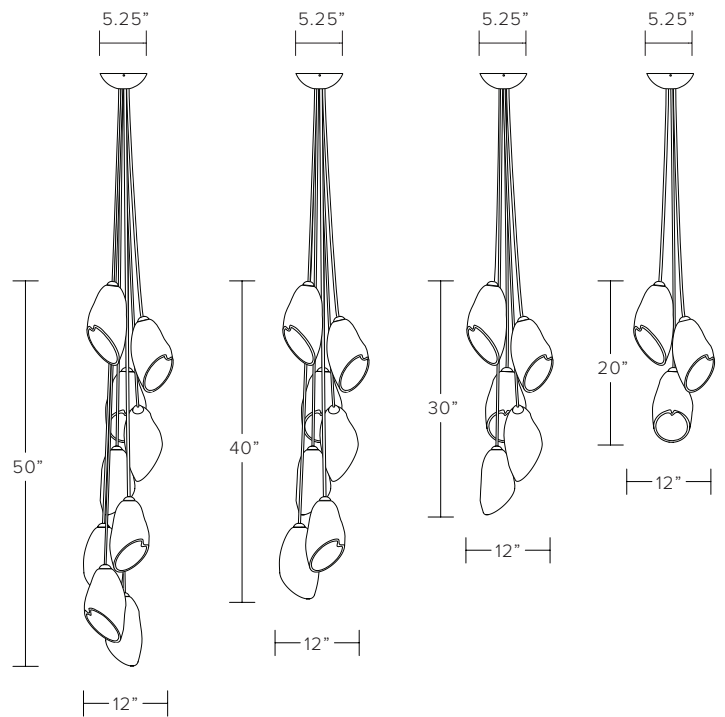



©2020 JOHN POMP STUDIOS (U.S. PATENT PENDING)



JOHN POMP

ECLIPSE PENDANT



ECLIPSE PENDANT

MODEL NO: JPSEPEL-01

MODEL NO: JPSEPES-01

Two-tone glass crystal pendants, masterfully hand-blown and sculpted to shape. Undulating hand carved opening, elegantly suspended on rigid stems.

AS SHOWN (IN PHOTO)

Glass - Two-tone soft etched white and soft etched clear crystal
 Metal - oil rubbed blackened steel

DIMENSIONS

Available in 2 sizes:

Large - 12"W x 11"H x 6"D
 Small - 10"W x 9"H x 6"D

Glass dimensions may vary slightly due to sculpted process

CONFIGURATIONS

Standard 5" diameter canopy provided per pendant with custom canopies and stem lengths available - pricing upon request

Various canopy and pendant configurations available - see custom configuration guides for more information

AVAILABLE FINISHES

Glass - Two-tone soft etched white and soft etched clear crystal (standard)

Metal - see metal finish list

ELECTRICAL

Large / Small - 40w incandescent bulb included
 4w LED alternative available

ADDITIONAL NOTES

Lead time is 10-12 weeks, additional 2-3 weeks for premium finishes.

Includes studio mark. UL listed.

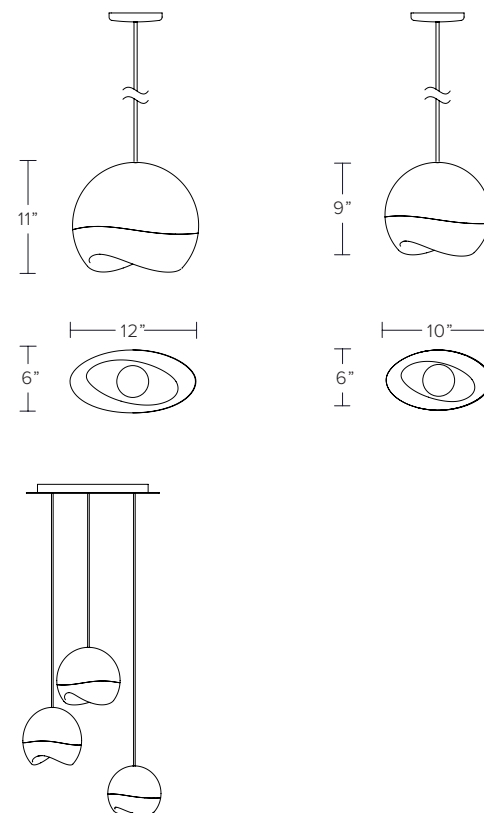



JOHN POMP

BUDDING PENDANT



BUDDING PENDANT

MODEL NO: JPSBPE-01

Hand-blown, organically sculpted glass crystal bud pendant suspended from stem and canopy

AS SHOWN (IN PHOTO)

Glass - soft etched crystal clear
Metal - satin brass

DIMENSIONS

Glass - approx. 9.5"W x 9.5"H

Glass dimensions may vary slightly due to sculpted process

AVAILABLE FINISHES

Glass - soft etched crystal clear (standard), soft etched quartz (standard), soft etched garnet, soft etched emerald

Metal - satin brass (standard), satin silver, satin copper, light oil rubbed blackened steel, oil rubbed blackened steel

ELECTRICAL

40w incandescent bulb per socket included

9w LED alternative available

ADDITIONAL NOTES

Lead time is 8-10 weeks, additional 2-3 weeks for premium finishes.

Includes studio mark. UL listed.

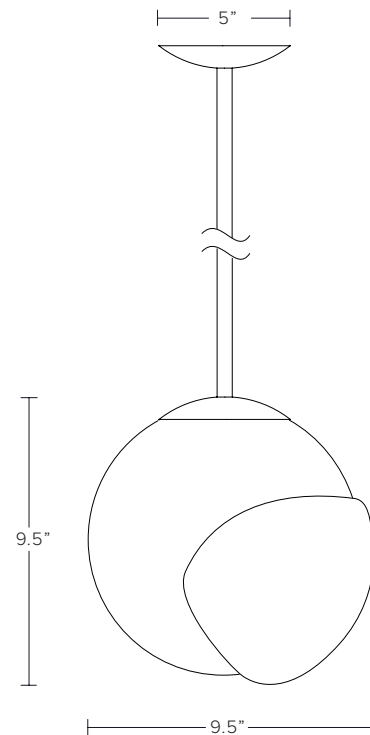



JOHN POMP

BUDDING SCONCE



BUDDING SCONCE

MODEL NO: JPSBSC-01

Hand-blown, organically sculpted glass crystal bud suspended from crescent-armed metal backplate

AS SHOWN (IN PHOTO)

Glass - soft etched crystal clear
Metal - satin brass

DIMENSIONS

Available in two sizes:

1 arm, 12"H x 6"W x 8.5"D

2 arm, 19.5"H x 14.5"W x 7.75"D

Glass - approx. 5" x 7"

Glass dimensions may vary slightly due to sculpted process

AVAILABLE FINISHES

Glass - soft etched crystal clear (standard), soft etched quartz (standard), soft etched garnet, soft etched emerald

Metal - satin brass (standard), satin silver, satin copper, light oil rubbed blackened steel, oil rubbed blackened steel

ELECTRICAL

25w incandescent bulb per socket included

4w LED alternative available

ADDITIONAL NOTES

Lead time is 8-10 weeks, additional 2-3 weeks for premium finishes.

Includes studio mark.

Requires 3.5" round j-box. UL listed.

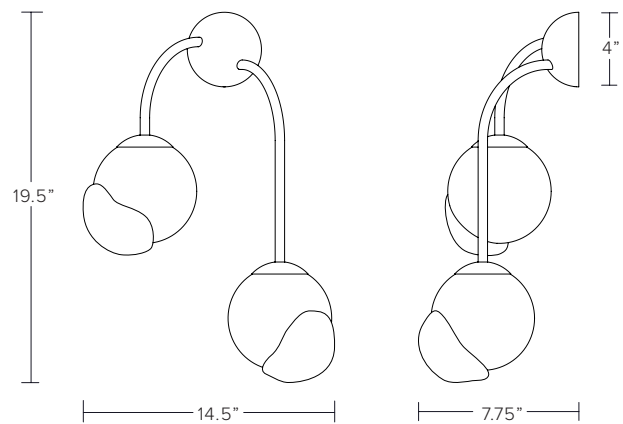
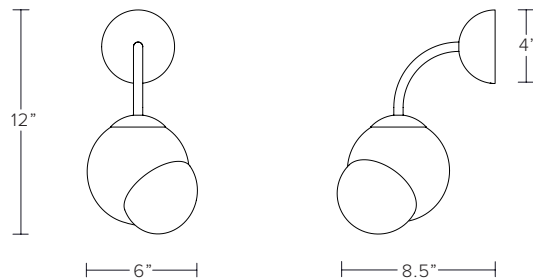



JOHN POMP

MOON ORCHID - CREST SCONCE



MOON ORCHID - CREST SCONCE

MODEL NO: JPSMOCRSC-01

Two hand-blown, sculpted glass crystal shades sprouting from brass crescent arms on metal backplate

AS SHOWN (IN PHOTO)

Glass - soft etched crystal clear
Metal - satin brass

DIMENSIONS

34.5"H x 4"W x 5.5"D

Glass - approx. 6" x 4"

Glass dimensions may vary slightly due to sculpted process

AVAILABLE FINISHES

Glass - soft etched crystal clear (standard), soft etched quartz (standard), soft etched garnet, soft etched emerald

Hand-etched glass has naturally variegated surface

Metal - satin brass (standard), satin silver, satin copper, light oil rubbed blackened steel, oil rubbed blackened steel

ELECTRICAL

25w incandescent bulb per socket included

4w LED alternative available

ADDITIONAL NOTES

Lead time is 8-10 weeks, additional 2-3 weeks for premium finishes.

Includes studio mark.

Requires 3.5" round j-box. UL listed.

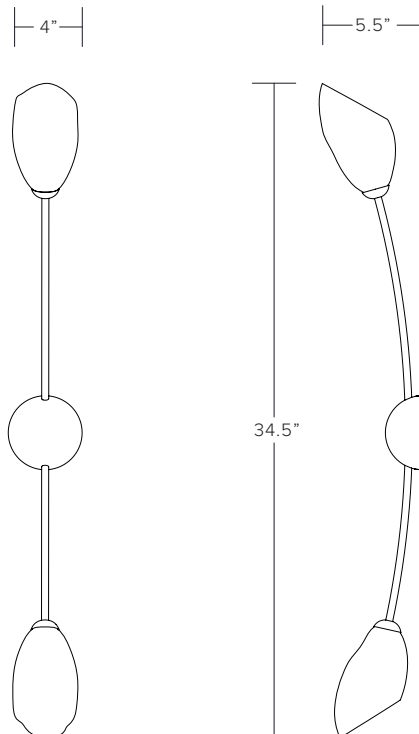



JOHN POMP

MOON ORCHID SCENCE



MOON ORCHID SCONCE

MODEL NO: JPSMOSC-01

Hand-blown, sculpted glass crystal shade on metal backplate

AS SHOWN (IN PHOTO)

Glass - soft etched crystal clear
Metal - satin brass

DIMENSIONS

8.5"H x 5"W x 7.5"D

Glass - approx. 9" x 5"

Glass dimensions may vary slightly due to sculpted process

AVAILABLE FINISHES

Glass - soft etched crystal clear (standard), soft etched quartz (standard), soft etched garnet, soft etched emerald

Hand-etched glass has naturally variegated surface

Metal - satin brass (standard), satin silver, satin copper, light oil rubbed blackened steel, oil rubbed blackened steel

ELECTRICAL

25w incandescent bulb per socket included

4w LED alternative available

ADDITIONAL NOTES

Lead time is 8-10 weeks, additional 2-3 weeks for premium finishes.

Includes studio mark.

Requires 3.5" round j-box. UL listed.

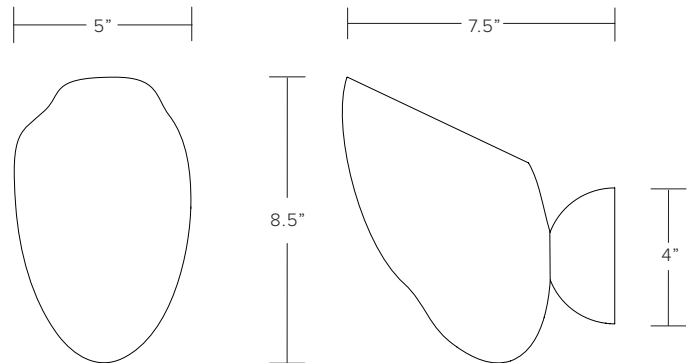



JOHN POMP

CLEAR BAND PENDANT



CLEAR BAND PENDANT

MODEL NO: JPSCBP-01

Hand-blown, sculpted glass crystal pendants, available in three different shapes with thick clear band lens.

AS SHOWN (IN PHOTO)

Glass - sepia
 Metal - oil rubbed blackened steel
 Wire - black with netting

DIMENSIONS

Available in 3 shapes:

Wide - 11"W x 8"H
 Sphere - 10.5"W x 10"H
 Long - 6.5"W x 12"H

Glass dimensions may vary slightly due to sculpted process

CONFIGURATIONS

Standard 5" diameter canopy provided per pendant with custom canopies and cord lengths available - pricing upon request

Various canopy and pendant/cluster configurations available - see custom configuration guides for more information

AVAILABLE FINISHES

See glass color and metal finish list

ELECTRICAL

Wide / Sphere - 40w or 60w incandescent bulb included
 5w LED alternative available

Long - 30w incandescent bulb included
 4w LED alternative available

ADDITIONAL NOTES

Lead time is 8-10 weeks, additional 2-3 weeks for premium finishes.

Includes studio mark. UL listed.

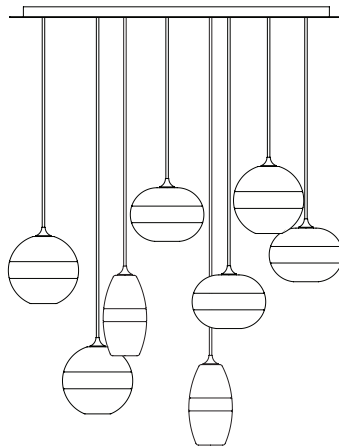
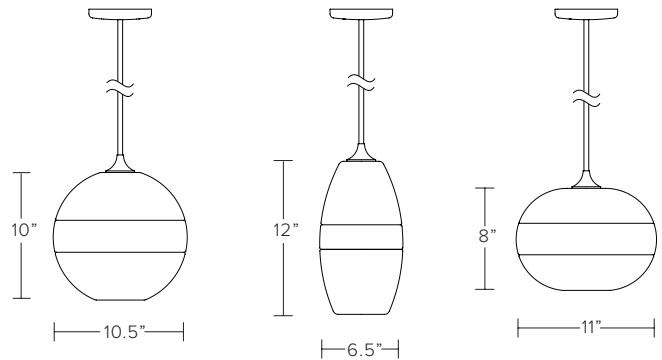



JOHN POMP

INFINITY PENDANT / INFINITY CLUSTER



INFINITY PENDANT

MODEL NO: JPSINPE-01

INFINITY CLUSTER

MODEL NO: JPSINCL-01

Hand-blown, sculpted glass crystal pendants

AS SHOWN (IN PHOTO)

Glass - clear with iridescence

Metal - oil rubbed blackened steel

Wire - black with netting

DIMENSIONS

Available in 2 sizes:

Pendant - 10"W x 11"H

Cluster - 6"W x 6"H (3 piece minimum)

Glass dimensions may vary slightly due to sculpted process

CONFIGURATIONS

Standard 5" diameter canopy provided per pendant with custom canopies and cord lengths available - pricing upon request

Various canopy and pendant/cluster configurations available - see custom configuration guides for more information

AVAILABLE FINISHES

See glass color and metal finish list

ELECTRICAL

Pendant - 40w or 60w incandescent bulb included
5w LED alternative available

Cluster - 6w or 15w incandescent bulb included
2w LED alternative available

ADDITIONAL NOTES

Lead time is 8-10 weeks, additional 2-3 weeks for premium finishes.

Includes studio mark. UL listed.

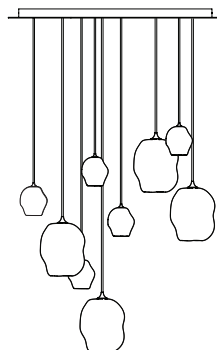
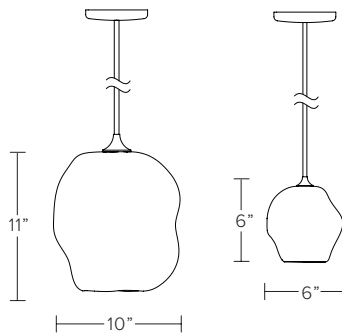



JOHN POMP

SPUN THREAD CLUSTER

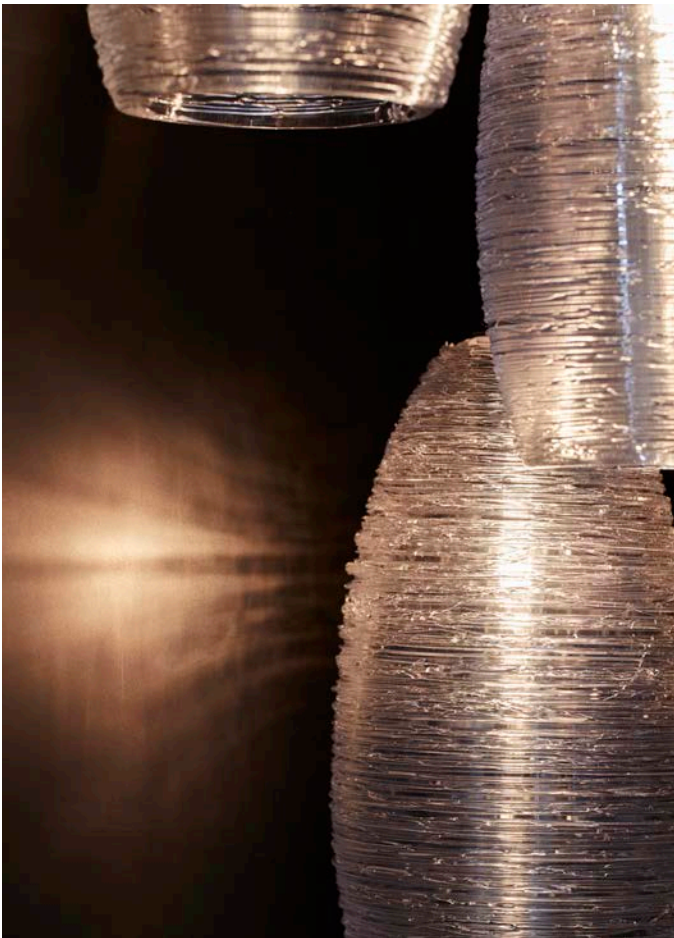

SPUN THREAD CLUSTER

MODEL NO: JPSSTPE-01

Hand-blown, glass crystal clusters with hand-applied molten glass threading, approximately 200 threads per piece

AS SHOWN (IN PHOTO)

Glass- clear
Metal - oil rubbed blackened steel
Wire - black with netting

DIMENSIONS

Approximately 5"W x 9"H (3 piece minimum)

Glass dimensions may vary slightly due to sculpted process

CONFIGURATIONS

Standard 5" diameter canopy provided per cluster with custom canopies and cord lengths available - pricing upon request

Various canopy and pendant/cluster configurations available - see custom configuration guides for more information

AVAILABLE FINISHES

Glass - clear or clear with iridescence
Canopy - see metal finish list

ELECTRICAL

15w incandescent bulb included
2w LED alternative available

ADDITIONAL NOTES

Lead time is 8-10 weeks, additional 2-3 weeks for premium finishes.
Includes studio mark. UL listed.

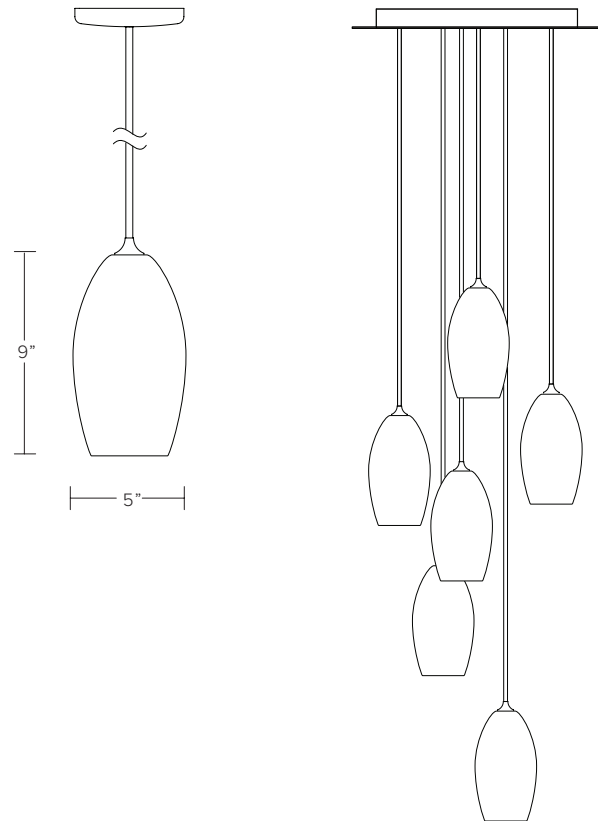



JOHN POMP

OPTIC MARBLE CLUSTER



OPTIC MARBLE CLUSTER

MODEL NO: JPSOMCL-01

Hand-blown, sculpted glass crystal clusters with multiple interior optic lenses

AS SHOWN (IN PHOTO)

Glass - smoke
Metal - oil rubbed blackened steel
Wire - black with netting

DIMENSIONS

Approximately 6" diameter (3 piece minimum)

Glass dimensions may vary slightly due to handmade process

CONFIGURATIONS

Standard 5" diameter canopy provided per pendant with custom canopies and cord lengths available - pricing upon request

Various canopy and pendant/cluster configurations available - see custom configuration guides for more information

AVAILABLE FINISHES

See glass color and metal finish list

ELECTRICAL

15w incandescent bulb included
2w LED alternative available

ADDITIONAL NOTES

Lead time is 8-10 weeks, additional 2-3 weeks for premium finishes.

Includes studio mark and craftsperson signature. UL listed.

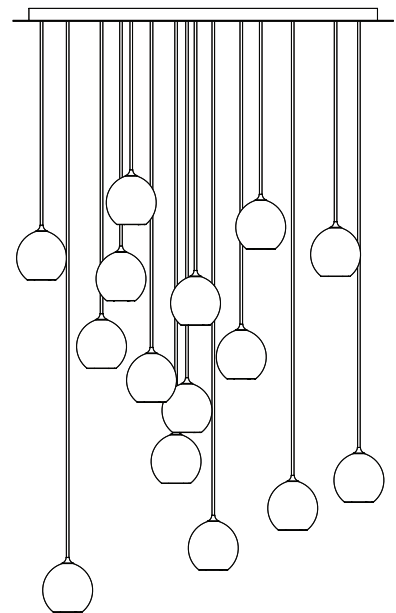
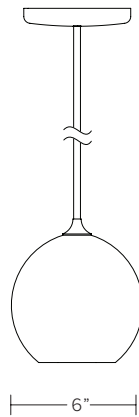



JOHN POMP

OPTIC MARBLE SCONCE



OPTIC MARBLE SCONCE

MODEL NO: JPSOMSC- 01

Hand-blown, sculpted glass crystal shade with multiple interior optic lenses on metal backplate

AS SHOWN (IN PHOTO)

Glass - clear with iridescence

Metal - light oil rubbed blackened steel

DIMENSIONS

12"H x 6.75"W x 7.75"D

Dimension for center of j-box access is 2.5" from bottom of backplate.

Glass dimensions may vary slightly due to sculpted process

AVAILABLE FINISHES

See glass color and metal finish list

ELECTRICAL

15w incandescent bulb included

2w LED alternative available

ADDITIONAL NOTES

Lead time is 8-10 weeks, additional 2-3 weeks for premium finishes.

Sconce can be oriented in opposite direction.

Includes studio mark. UL listed.

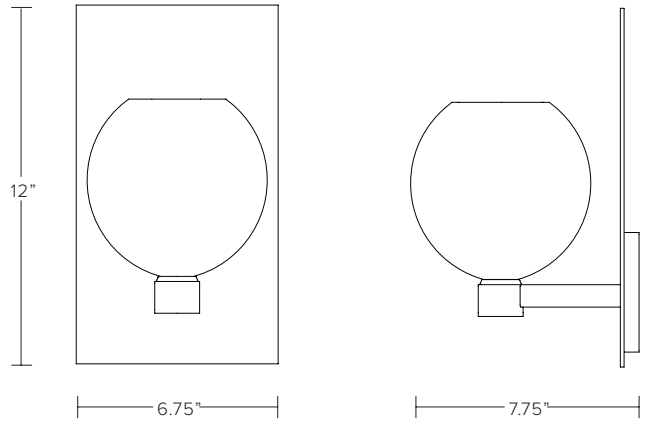



JOHN POMP

INFINITY SCONCE



INFINITY SCONCE

MODEL NO: JPSINSC-01

Hand-blown, sculpted glass crystal shade on metal backplate

AS SHOWN (IN PHOTO)

Glass - clear with iridescence

Metal - light oil rubbed blackened steel

DIMENSIONS

12"H x 6.75"W x 7.75"D

Dimension for center of j-box access is 2.5" from bottom of backplate.

Glass dimensions may vary slightly due to sculpted process

AVAILABLE FINISHES

See glass color and metal finish list

ELECTRICAL

6w or 15w incandescent bulb included

2w LED alternative available

ADDITIONAL NOTES

Lead time is 8-10 weeks, additional 2-3 weeks for premium finishes.

Sconce can be oriented in opposite direction.

Includes studio mark. UL listed.

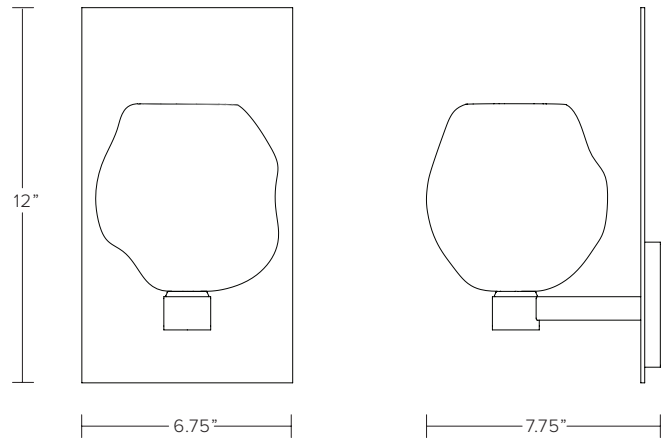



JOHN POMP

CLEAR BAND SCONCE



CLEAR BAND SCONCE

MODEL NO: JPSCBS-01

Hand-blown, sculpted glass crystal shade with thick clear optic lens on metal backplate

AS SHOWN (IN PHOTO)

Glass - clear

Metal - light oil rubbed blackened steel

DIMENSIONS

12"H x 6.75"W x 7.75"D

Dimension for center of j-box access is 2.5" from top of backplate.

Glass dimensions may vary slightly due to sculpted process

AVAILABLE FINISHES

See glass color and metal finish list

ELECTRICAL

6w or 15w incandescent bulb included

2w LED alternative available

ADDITIONAL NOTES

Lead time is 8-10 weeks, additional 2-3 weeks for premium finishes.

Sconce can be oriented in opposite direction.

Includes studio mark. UL listed.

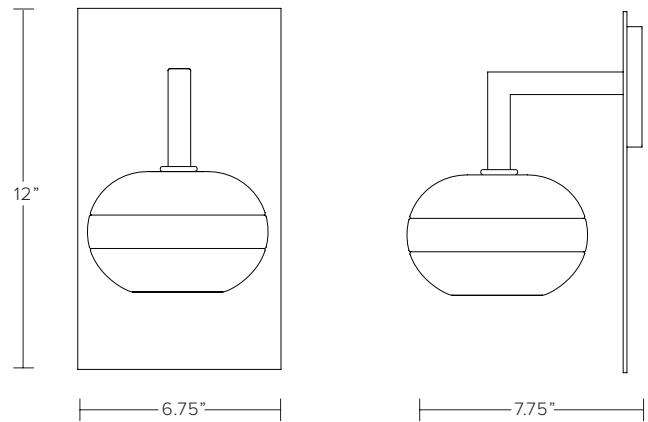



JOHN POMP

SPUN THREAD SCONCE



SPUN THREAD SCONCE

MODEL NO: JPSSTS-01

Hand-blown, sculpted glass crystal shade with hand-applied molten glass threading, approximately 200 threads per piece on metal backplate

AS SHOWN (IN PHOTO)

Glass - clear
Metal - light oil rubbed blackened steel

DIMENSIONS

13.25"H x 6.75"W x 6.75"D
Dimension for center of j-box access is 2.5" from top of backplate.

Glass dimensions may vary slightly due to sculpted process

AVAILABLE FINISHES

Glass - clear or clear with iridescence
Metal - see metal finish list

ELECTRICAL

15w incandescent bulb included
2w LED alternative available

ADDITIONAL NOTES

Lead time is 8-10 weeks, additional 2-3 weeks for premium finishes.
Includes studio mark. UL listed.

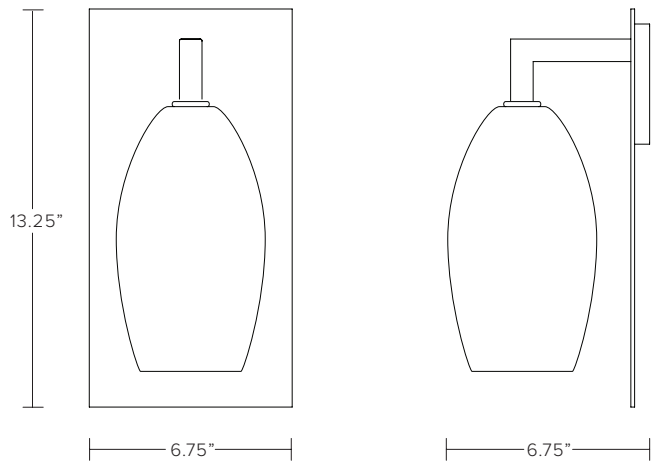



JOHN POMP

LUMENARIUMS



LUMENARIUMS

MODEL NO: JPSLH-01 (HIGH) JPSLL-01 (LOW)

Hand-blown, sculpted glass crystal cloches in milky white ombré on metal base with varying bulb sizes

AS SHOWN (IN PHOTO)

Glass - milky white ombré
Metal - oil rubbed bronze metal base

DIMENSIONS

Available in 2 sizes:

High - 16.25"H x 10"W

Low - 11"H x 10"W

Glass dimensions may vary slightly due to sculpted process

AVAILABLE FINISHES

Glass - available in milky white to clear fade

Metal - see metal finish list

ELECTRICAL

Low and High - 5 incandescent bulbs included, varying wattage (25w-40w)

8' of wire plus dimmer

ADDITIONAL NOTES

Lead time is 10-12 weeks. additional 2-3 weeks for premium finishes.

Includes studio mark and craftsman signature. UL listing not available.

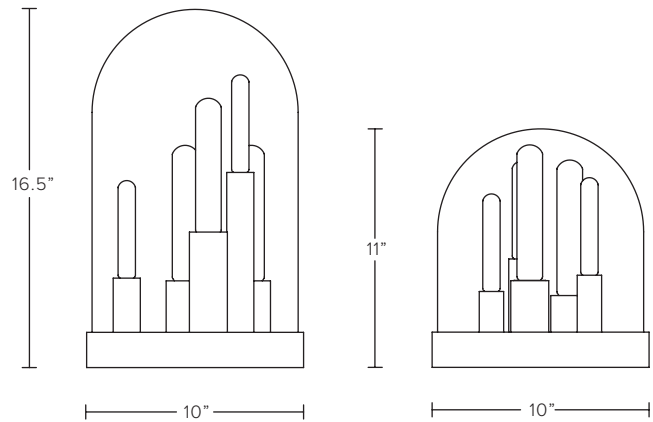



©2020 JOHN POMP STUDIOS (U.S. PATENT NO. D803,467)



JOHN POMP

CLEAR BAND FLOOR LAMP



CLEAR BAND FLOOR LAMP

MODEL NO: JPSCBFL-01

Hand-blown, sculpted glass crystal pendant suspended by black woven cordage on an oil rubbed blackened steel base with a brass bar switch

AS SHOWN (IN PHOTO)

Glass - smoke
Metal - oil rubbed blackened steel
Wire - black woven cordage

DIMENSIONS

68"H x 14" diameter base

Glass dimensions may vary slightly due to sculpted process

AVAILABLE FINISHES

Glass - see glass finish list

Metal - oil rubbed blackened steel or light oil rubbed blackened steel
with brass details (brass components will naturally patina over time)

ELECTRICAL

30w incandescent bulb included
2w LED alternative available

ADDITIONAL NOTES

Lead time is 8-10 weeks, additional 2-3 weeks for premium finishes.

Includes studio mark. UL listed.

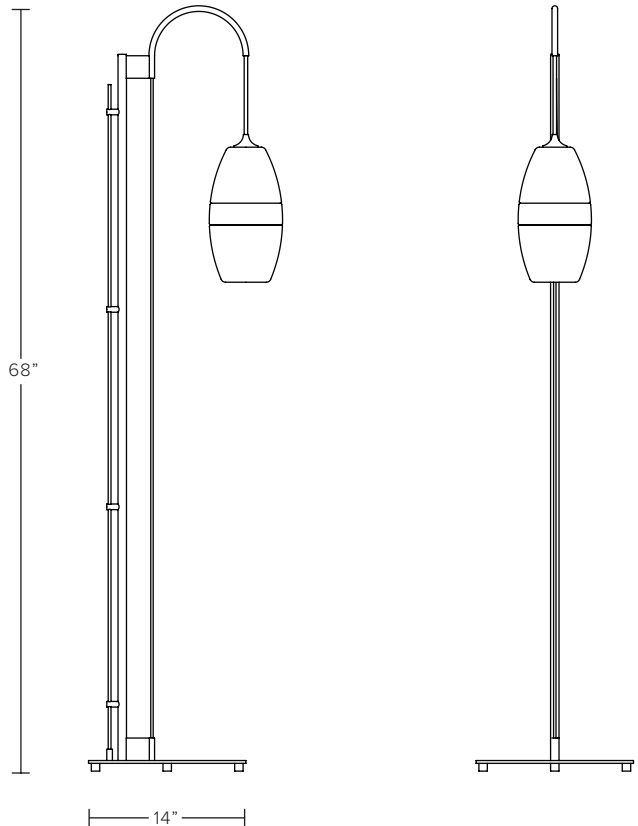



JOHN POMP

DROPLET SIDE TABLE



DROPLET SIDE TABLE

MODEL NO: JPSTDSTABLE-01

Hand-poured, clear glass crystal table top with hand-sculpted droplet inclusion on metal base

AS SHOWN (IN PHOTO)

Metal - antique brass

DIMENSIONS

Available in three sizes:

Large Glass - .875" thick x 15.75" diameter
Metal - 25"H x 18"W

Medium Glass - .875" thick x 13.5" diameter
Metal - 23.5"H x 15.5"W

Small Glass - .875" thick x 11.5" diameter
Metal - 22"H x 14"W

AVAILABLE FINISHES

Glass - hand-poured clear glass crystal with hand-sculpted inclusion

Metal - see metal finish list

ADDITIONAL NOTES

Lead time is 10-12 weeks, additional 2-3 weeks for premium finishes.

Includes studio mark.

Droplet inclusion placement varies.

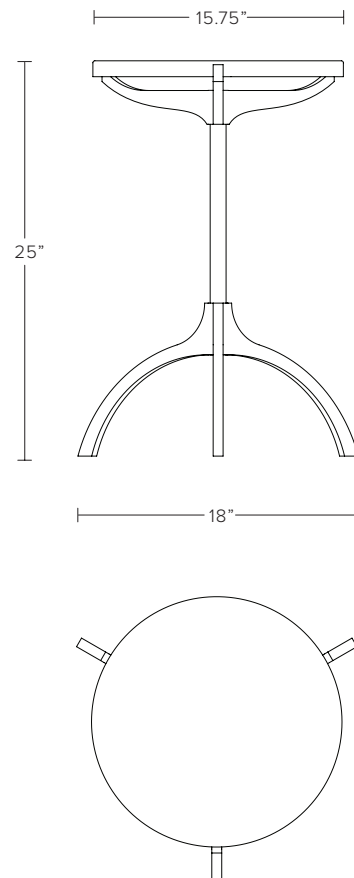



JOHN POMP

STITES SIDE TABLE



STITES SIDE TABLE

MODEL NO: JPSSST-01

Hand-poured, layered clear glass crystal table top on satin pale bronze metal base with hand-turned wood legs

AS SHOWN (IN PHOTO)

Metal - satin pale bronze
Wood - dark walnut

DIMENSIONS

Overall - 21.5"W x 23"H

AVAILABLE FINISHES

Glass - hand-poured, layered clear glass crystal
Metal - satin pale bronze
Wood - white ash, medium walnut or dark walnut

ADDITIONAL NOTES

Lead time is 12-14 weeks.
Includes studio mark.

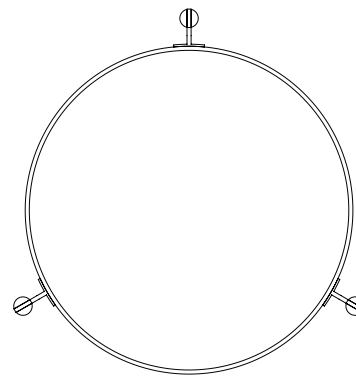
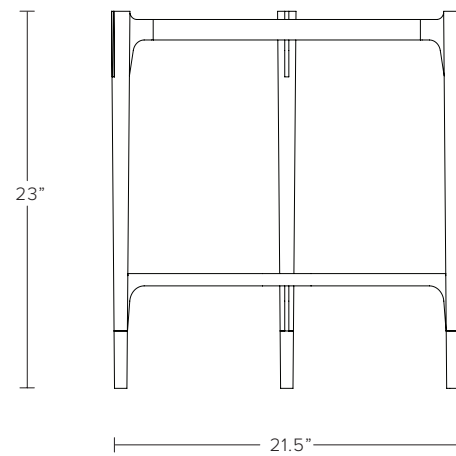



JOHN POMP

STITES CIRCULAR COCKTAIL TABLE



STITES CIRCULAR COCKTAIL TABLE

MODEL NO: JPSSCT-01

Hand-cast, clear glass crystal table top with constellation inspired bubble pattern top on satin pale bronze metal base with hand-turned wood legs

AS SHOWN (IN PHOTO)

Metal - satin pale bronze
Wood - dark walnut

DIMENSIONS

Overall - 45"W x 16.5"H

AVAILABLE FINISHES

Glass - hand-poured, clear glass crystal with constellation inspired bubble pattern

Metal - satin pale bronze

Wood - white ash, medium walnut or dark walnut

ADDITIONAL NOTES

Lead time is 12-14 weeks.

Includes studio mark.

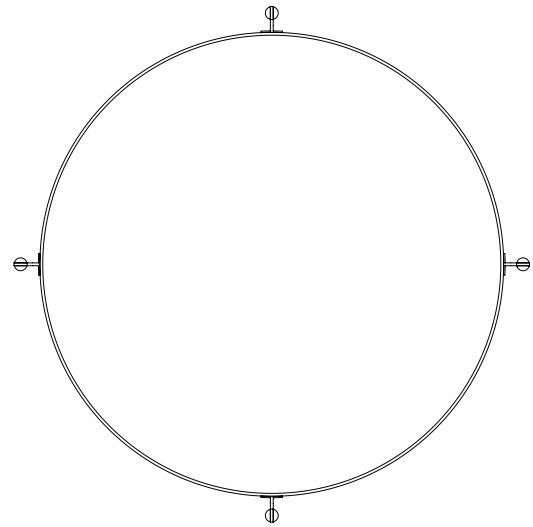
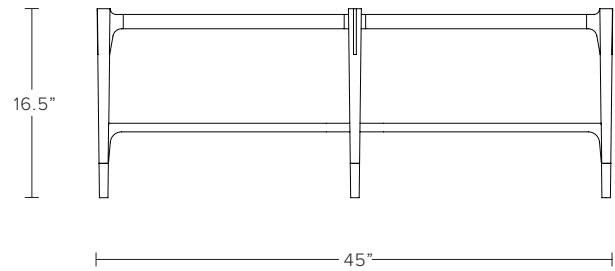



JOHN POMP

STITES RECTANGULAR COCKTAIL TABLE



STITES RECTANGULAR COCKTAIL TABLE

MODEL NO: JPSSRT-01

Hand-cast, clear glass crystal table top with constellation inspired bubble pattern top on satin pale bronze metal base with hand-turned wood legs

AS SHOWN (IN PHOTO)

Metal - satin pale bronze metal base
Wood - dark walnut

DIMENSIONS

Overall - 65"L x 31"W x 16.5"H

AVAILABLE FINISHES

Glass - hand-poured, clear glass crystal with constellation inspired bubble pattern

Metal - satin pale bronze

Wood - white ash, medium walnut or dark walnut

ADDITIONAL NOTES

Lead time is 12-14 weeks.

Includes studio mark.

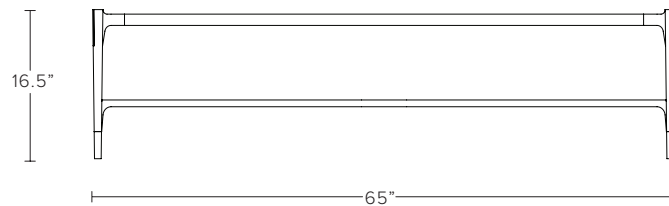



JOHN POMP

TIDAL SIDE TABLE



TIDAL SIDE TABLE

MODEL NO: JPSTST-01

Hand-poured, meniscus glass crystal table top on sculpted metal base with polished details

AS SHOWN (IN PHOTO)

Glass - clear crystal
Metal - brushed brass

DIMENSIONS

21"L x 14"W x 20.5"H

AVAILABLE FINISHES

Glass - clear crystal, emerald flowing to clear, garnet flowing to clear, smoke flowing to clear

Metal - brushed brass, brushed silver, brushed copper, light oil rubbed blackened steel, oil rubbed blackened steel

ADDITIONAL NOTES

Lead time is 10-12 weeks, additional 2-3 weeks for premium glass colors.

Includes studio mark.

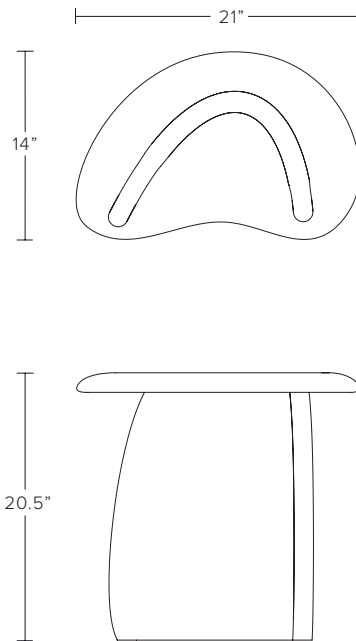
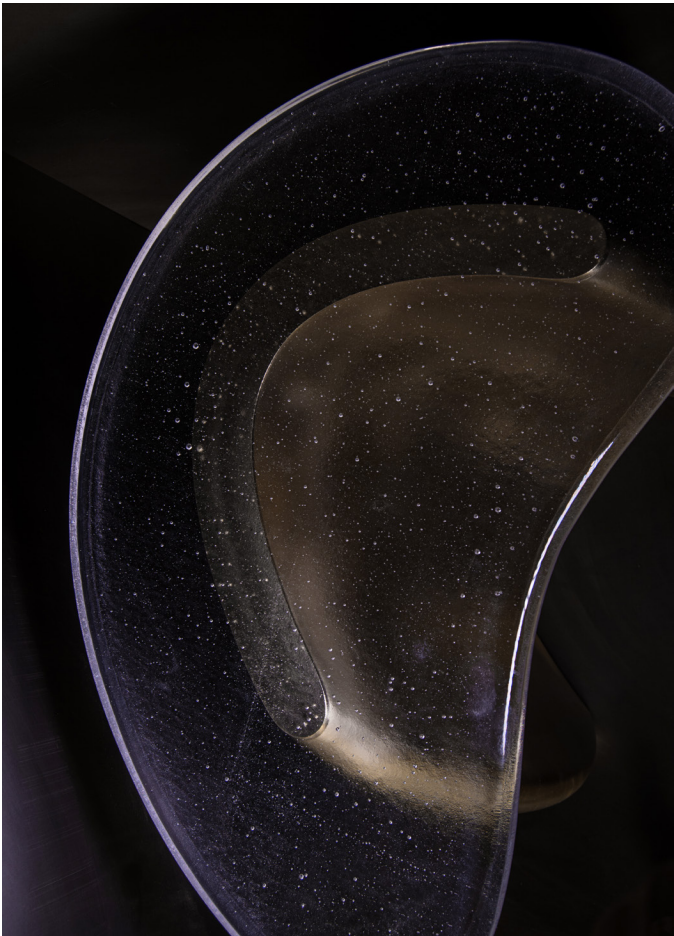



JOHN POMP

TIDAL CONSOLE



TIDAL CONSOLE

MODEL NO: JPSTCO-01

Hand-poured, meniscus glass crystal table top on sculpted metal base with polished details

AS SHOWN (IN PHOTO)

Glass - clear crystal
Metal - brushed brass

DIMENSIONS

71"L x 16"W x 30"H

AVAILABLE FINISHES

Glass - clear crystal, emerald flowing to clear, garnet flowing to clear, smoke flowing to clear

Metal - brushed brass, brushed silver, brushed copper, light oil rubbed blackened steel, oil rubbed blackened steel

ADDITIONAL NOTES

Lead time is 10-12 weeks, additional 2-3 weeks for premium glass colors.
Includes studio mark.

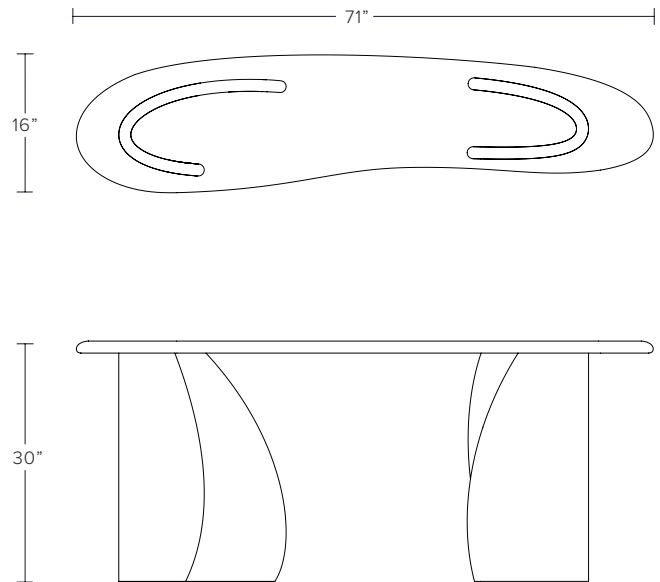



JOHN POMP

TIDAL COCKTAIL TABLE



TIDAL COCKTAIL TABLE

MODEL NO: JPSTCT-01

Hand-poured, meniscus glass crystal table top on sculpted metal base with polished details

AS SHOWN (IN PHOTO)

77"L x 33"W x 17"H

Glass - garnet flowing to clear

Metal - brushed brass

DIMENSIONS

Available in two sizes:

77"L x 33"W x 17"H

60"L x 28"W x 16"H

AVAILABLE FINISHES

Glass - clear crystal, emerald flowing to clear, garnet flowing to clear, smoke flowing to clear

Metal - brushed brass, brushed silver, brushed copper, light oil rubbed blackened steel, oil rubbed blackened steel

ADDITIONAL NOTES

Lead time is 10-12 weeks, additional 2-3 weeks for premium glass colors.

Includes studio mark.

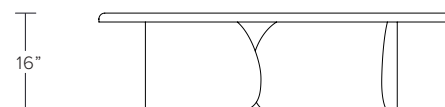
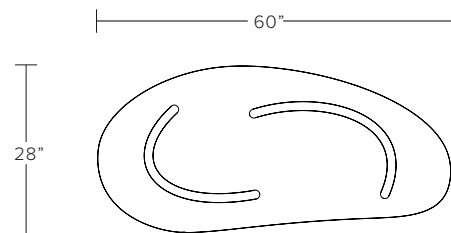
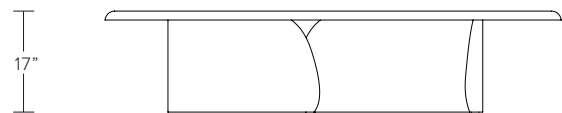
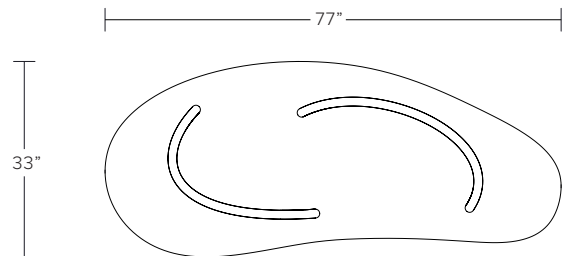



JOHN POMP

TIDAL RECTANGULAR COCKTAIL TABLE



TIDAL RECTANGULAR COCKTAIL TABLE

MODEL NO: JPSTRCT-01

Hand-poured, meniscus glass crystal table top on sculpted metal base with polished details

AS SHOWN (IN PHOTO)

60"L x 30"W x 16.5"H

Glass - clear crystal

Metal - light oil rubbed blackened steel

DIMENSIONS

60"L x 30"W x 16.5"H

custom sizing upon request

AVAILABLE FINISHES

Glass - clear crystal, emerald flowing to clear, garnet flowing to clear, smoke flowing to clear

Metal - brushed brass, brushed silver, brushed copper, light oil rubbed blackened steel, oil rubbed blackened steel

ADDITIONAL NOTES

Lead time is 10-12 weeks, additional 2-3 weeks for premium glass colors.

Includes studio mark.

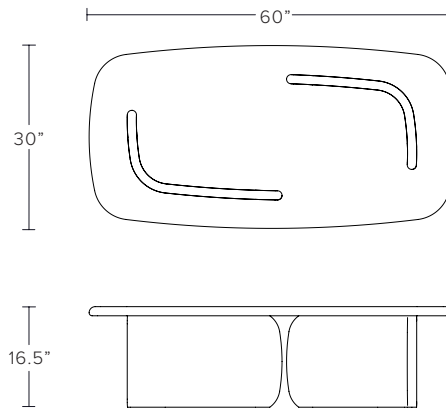



JOHN POMP

RONDELLE SIDE TABLE



RONDELLE SIDE TABLE

MODEL NO: JPSRST-01

Hand-blown, clear glass crystal rondelle drawer face on metal frame with wood panels, leather lined shelf and wood drawer, metal hardware details with flame-cut metal top

AS SHOWN (IN PHOTO)

Metal - frame: oil rubbed blacked steel
top: antique brass
glass hardware: brass
Wood - ebonized ash
Leather - black

DIMENSIONS

Overall - 25"L x 18"W x 25"H

AVAILABLE FINISHES

Wood - white ash, oxidized walnut, medium walnut, or ebonized ash

Metal - frame: metal brushed steel, light oil rubbed blackened steel, or oil rubbed blackened steel,
top: satin nickel, antique brass, or oxidized brass

Leather - hand-stitched natural tan, bourbon brown, or black leather

Glass/handle hardware - silver or brass

ADDITIONAL NOTES

Lead time is 10-12 weeks.

Includes studio mark signature.

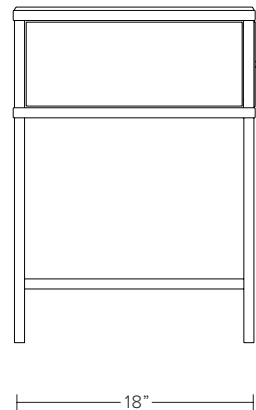
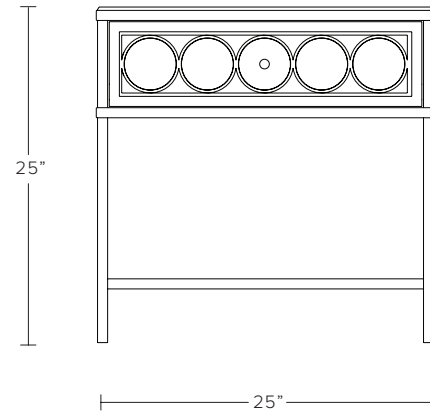



JOHN POMP

RONDELLE CONSOLE



RONDELLE CONSOLE

MODEL NO: JPSRCO-01

Hand-blown, clear glass crystal rondelle drawer faces on metal frame with wood panels, hand-stitched leather shelf and leather lined wood drawers, metal hardware details with flame-cut metal top

AS SHOWN (IN PHOTO)

Metal - frame: light oil rubbed blackened steel
top: oxidized brass
hardware: brass
Leather - bourbon brown
Wood - medium walnut

DIMENSIONS

Overall - 72"L x 18"D x 34"H (3 drawers)

AVAILABLE FINISHES

Wood - white ash, oxidized walnut, medium walnut, or ebonized ash
Metal - frame: metal brushed steel, light oil rubbed blackened steel, or oil rubbed blackened steel,
top: satin nickel, antique brass, or oxidized brass
Leather - hand-stitched natural tan, bourbon brown, or black leather
Glass/handle hardware - silver or brass

ADDITIONAL NOTES

Lead time is 12-14 weeks.

Includes studio mark.

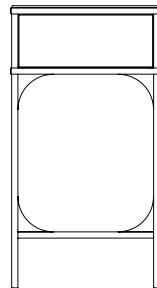
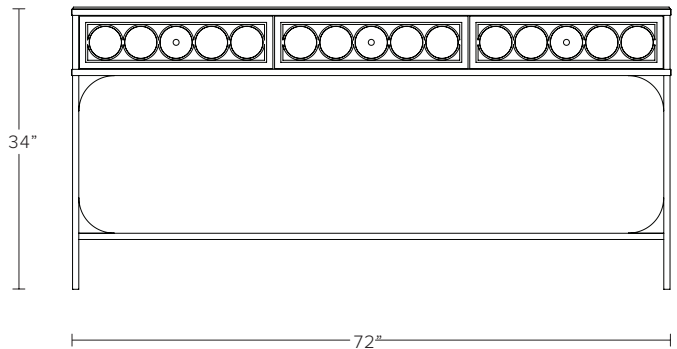
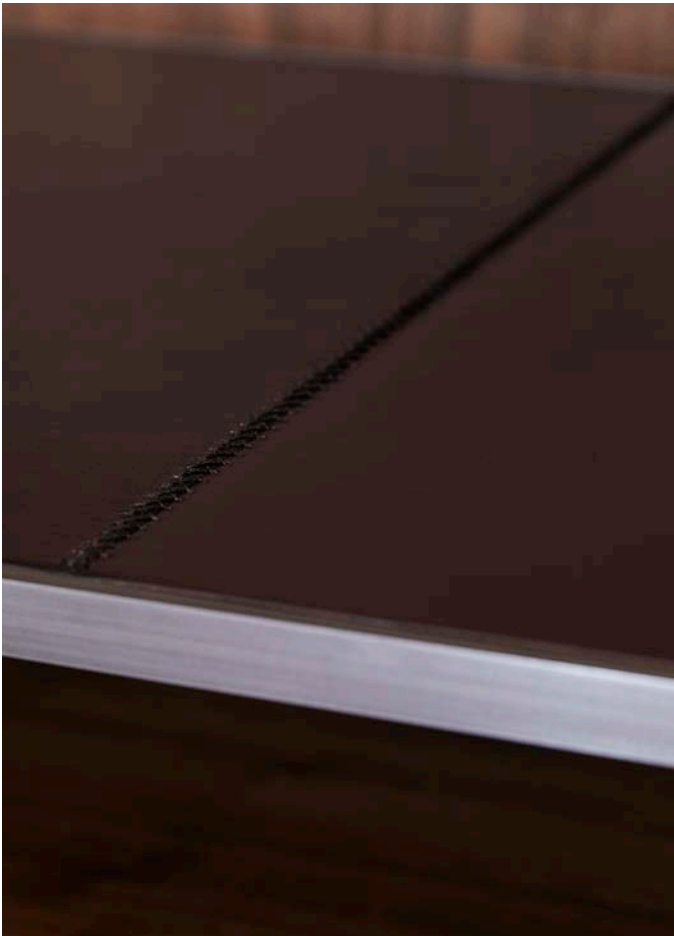

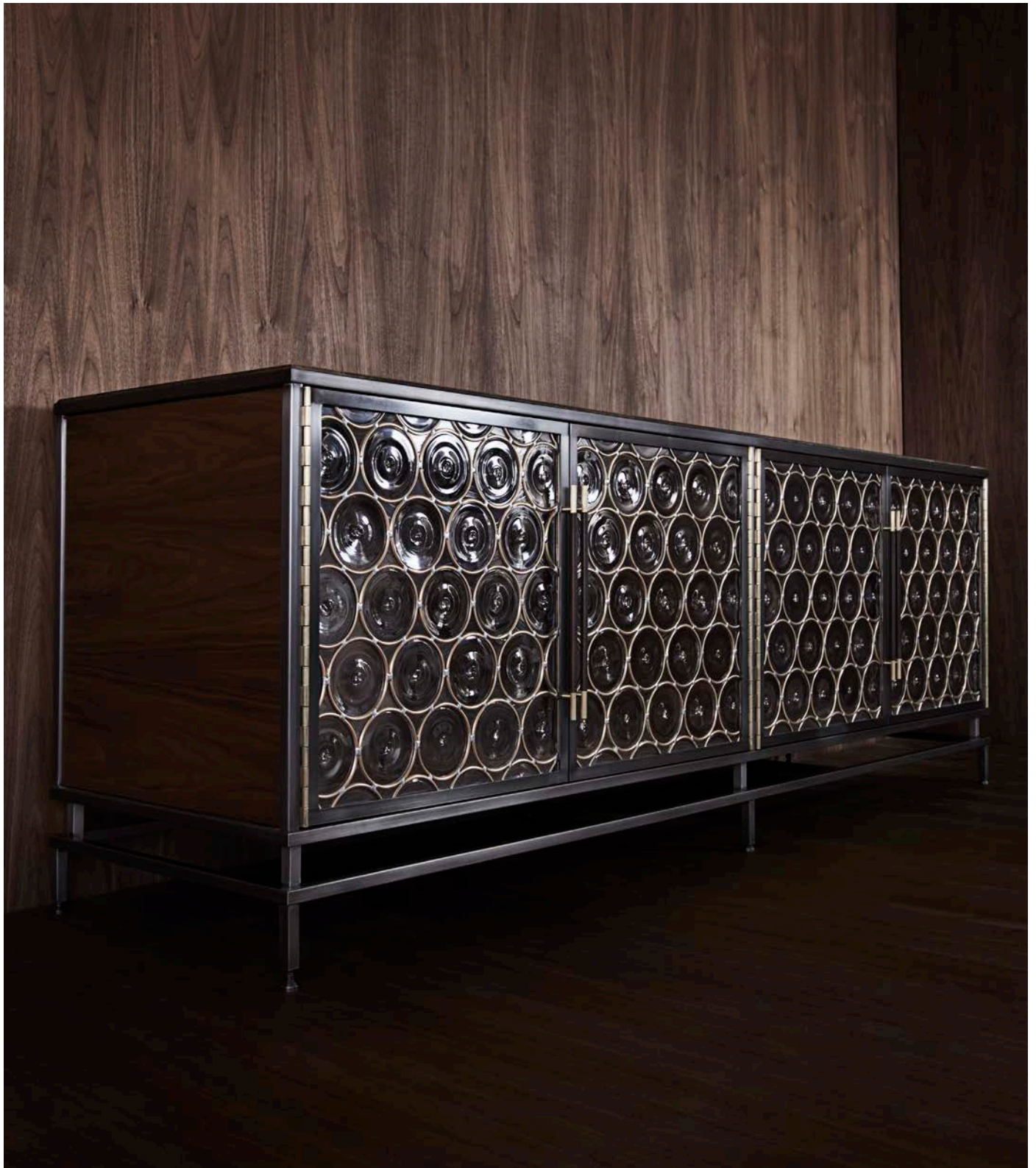

©2020 JOHN POMP STUDIOS (U.S. PATENT NO. D777336)



JOHN POMP

RONDELLE CREDENZA

RONDELLE CREDENZA

MODEL NO JPSRCR—01

Hand-blown, clear glass crystal rondelle door faces on metal frame with wood panels, metal hardware and hand-stitched leather details, adjustable interior wood shelving with flame-cut metal top

AS SHOWN (IN PHOTO)

88"L x 22"D x 30"H (4 doors)

Metal - frame: light oil rubbed blackened steel

top: oxidized brass

hardware: brass

Wood - medium walnut

Leather - bourbon brown

DIMENSIONS

Available in three lengths and two heights:

Low

Overall - 60"L x 22"D x 25"H (2 doors)

Overall - 74"L x 22"D x 25"H (2 doors)

Overall - 88"L x 22"D x 25"H (4 doors)

High

Overall - 60"L x 22"D x 30"H (4 doors)

Overall - 74"L x 22"D x 30"H (4 doors)

Overall - 88"L x 22"D x 30"H (4 doors)

AVAILABLE FINISHES

Wood - white ash, oxidized walnut, medium walnut, or ebonized ash

Metal - frame: metal brushed steel, light oil rubbed blackened steel, or oil rubbed blackened steel,
top: satin nickel, antique brass, or oxidized brass

Leather - hand-stitched natural tan, bourbon brown, or black leather

Glass/handle hardware - silver or brass

ADDITIONAL NOTES

Lead time is 12—14 weeks.

Custom sizes available upon request.

Includes studio mark.

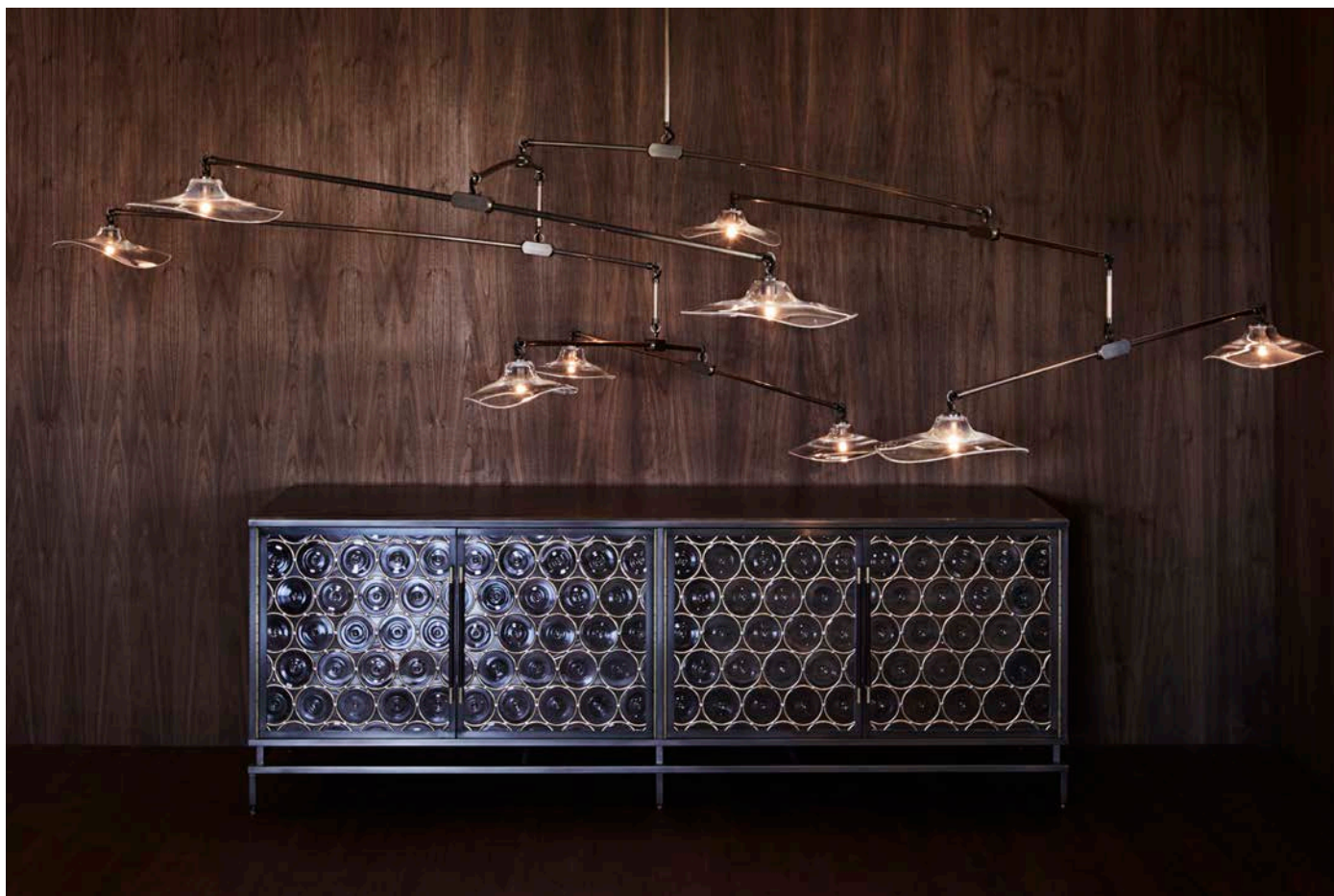

Rondelle Credenza 88"L x 22"D x 30"H (4 doors) with 9 piece Calla Mobile

LOW STYLE

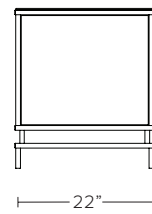
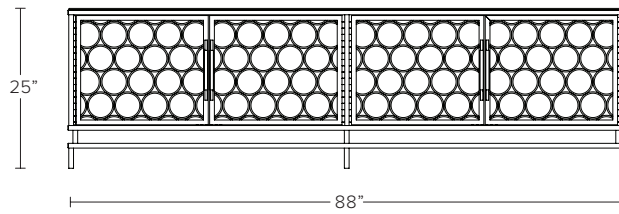
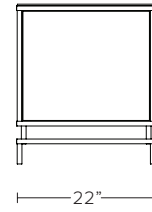
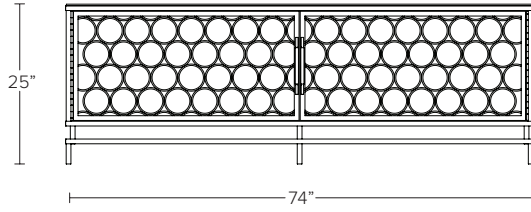
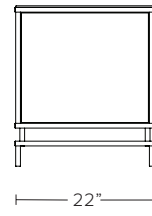
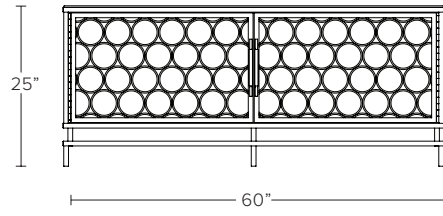

HIGH STYLE

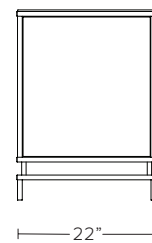
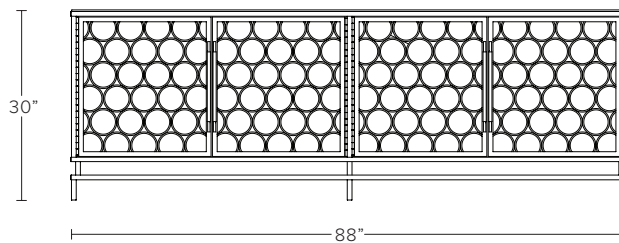
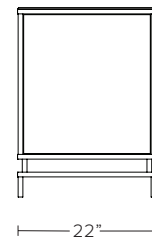
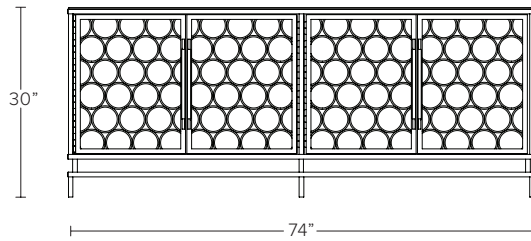
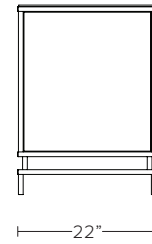
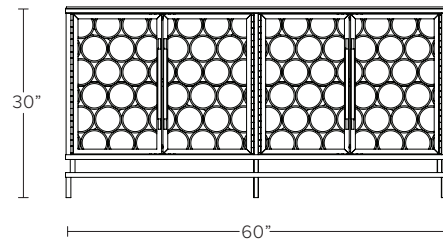



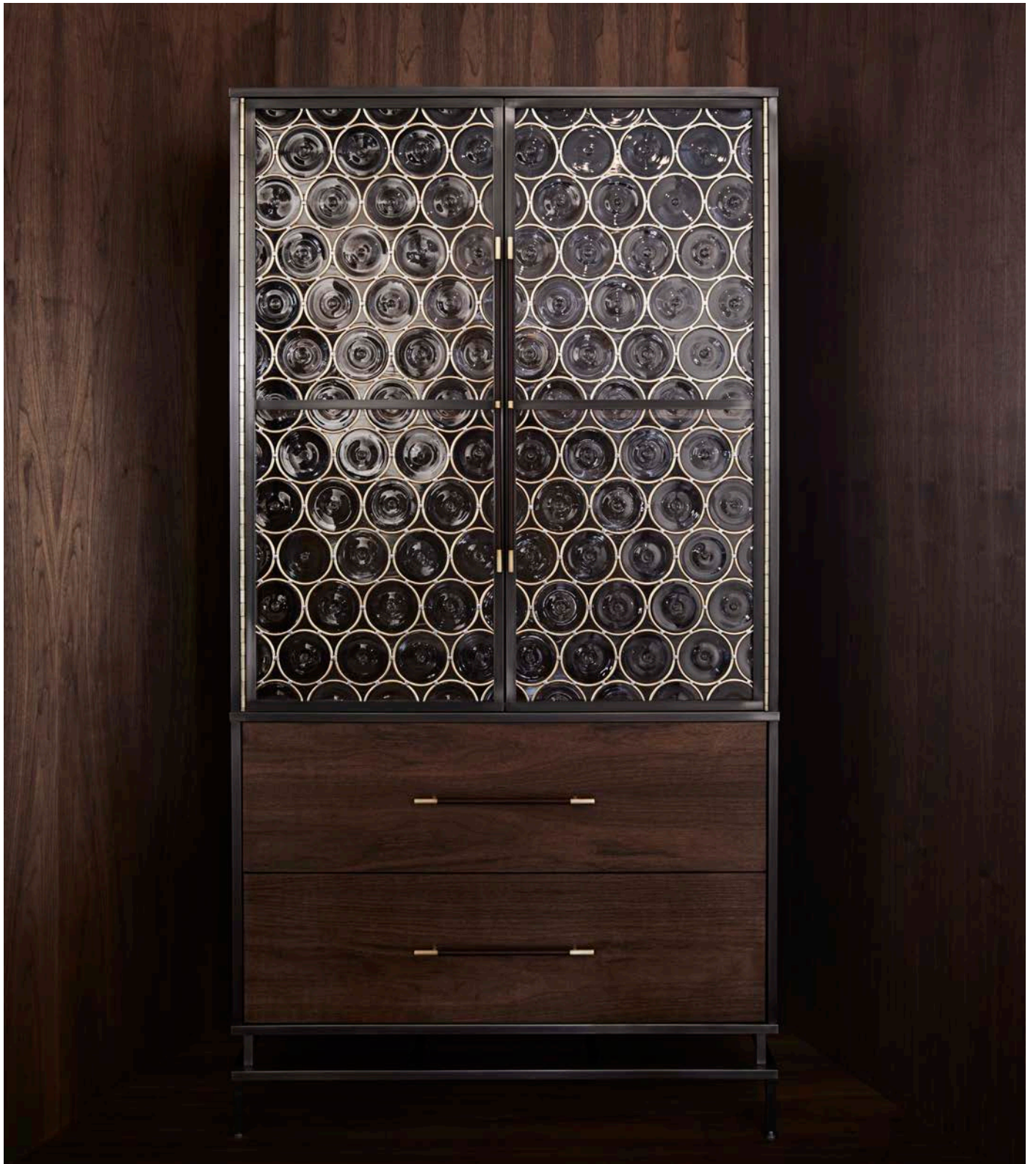

JOHN POMP

RONDELLE ARMOIRE



RONDELLE ARMOIRE

MODEL NO: JPSRA-01

Hand-blown, clear glass crystal rondelle door faces on metal frame with wood panels, leather lined wood drawers and adjustable interior wood shelving, metal hardware and hand-stitched leather details

AS SHOWN (IN PHOTO)

Metal - frame: light oil rubbed blackened steel
hardware: brass

Wood - medium walnut
Leather - bourbon brown

DIMENSIONS

Overall - 80"H x 42"W x 22"D (2 doors / 2 drawers)

AVAILABLE FINISHES

Wood - white ash, oxidized walnut, medium walnut, or ebonized ash

Metal - frame: metal brushed steel, light oil rubbed blackened steel, or oil rubbed blackened steel,

Leather - hand-stitched natural tan, bourbon brown, or black leather

Glass/handle hardware - silver or brass

ADDITIONAL NOTES

Lead time is 12-14 weeks. Wall mounting bracket included.

Includes studio mark.

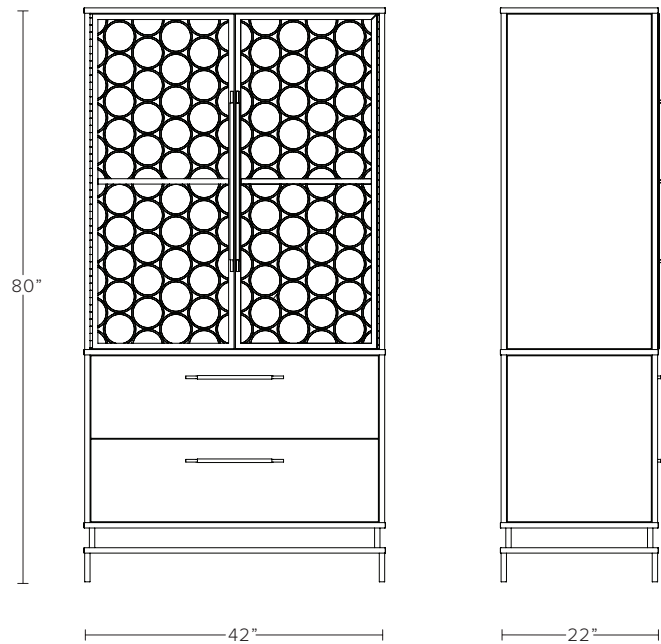



JOHN POMP

BETHLEHEM CREDENZA



BETHLEHEM CREDENZA

MODEL NO: JPSBC-01

Metal patina doors on metal frame with wood panels and adjustable interior wood shelving, hand-turned walnut legs, brass screw details, distressed leather pulls with flame-cut metal top

AS SHOWN (IN PHOTO)

88"L x 22"D x 28"H (4 doors)

Metal - frame: oil rubbed blackened steel
top: oxidized brass

Wood - panel: ebonized ash
legs: walnut

DIMENSIONS

Available in 3 sizes:

Overall - 60"L x 22"D x 28"H (2 doors)

Overall - 74"L x 22"D x 28"H (4 doors)

Overall - 88"L x 22"D x 28"H (4 doors)

AVAILABLE FINISHES

Wood - ebonized ash, medium walnut, or dark walnut panels; hand turned walnut legs

Metal - antique brass or oxidized brass top; oil rubbed blackened steel or light oil rubbed blackened steel frame and doors

Leather - distressed leather pulls

ADDITIONAL NOTES

Lead time is 12-14 weeks.

Includes studio mark.

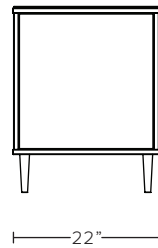
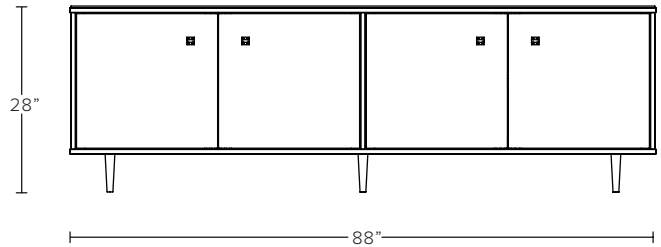



JOHN POMP

BONHAM LOUNGE CHAIR / BONHAM OTTOMAN



BONHAM LOUNGE CHAIR

MODEL NO: JPSBLC-01

BONHAM OTTOMAN

MODEL NO: JPSBOTT-01

Tufted, distressed leather cushion on metal frame with brass embellishments; chair includes a detachable, brass-weighted headrest pillow

AS SHOWN (IN PHOTO)

Chair:

Metal - light oil rubbed blackened steel with brass embellishments

Leather - distressed ocean blue

Ottoman:

Metal - light oil rubbed blackened steel with brass embellishments

Leather - distressed ocean blue

DIMENSIONS

Chair - Overall dimensions - 41"H x 34"W x 35"D

Arm height - 22"H

Seat height with cushion - 17"H

Ottoman - Overall dimensions - 26"W x 26"D x 17"H

AVAILABLE FINISHES

Frame - oil rubbed blackened steel or light oil rubbed blackened steel with brass embellishments

Leather - distressed midnight black, distressed ocean blue or distressed bourbon brown with black or brown strapping.

ADDITIONAL NOTES

Lead time is 10-12 weeks. COL - 100sqft (chair), 50sqft (ottoman)

Includes studio mark.

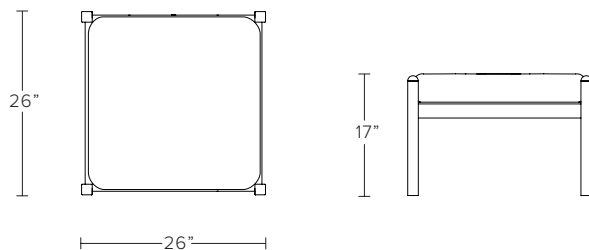
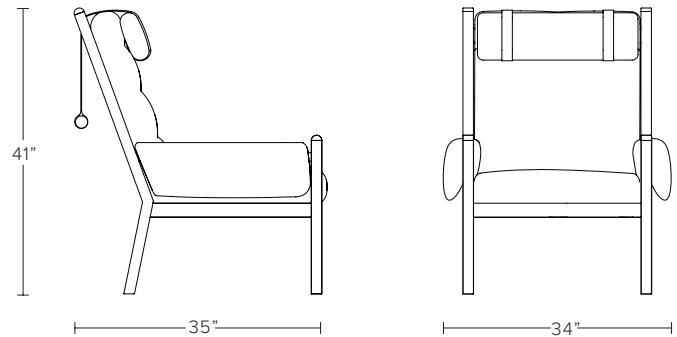
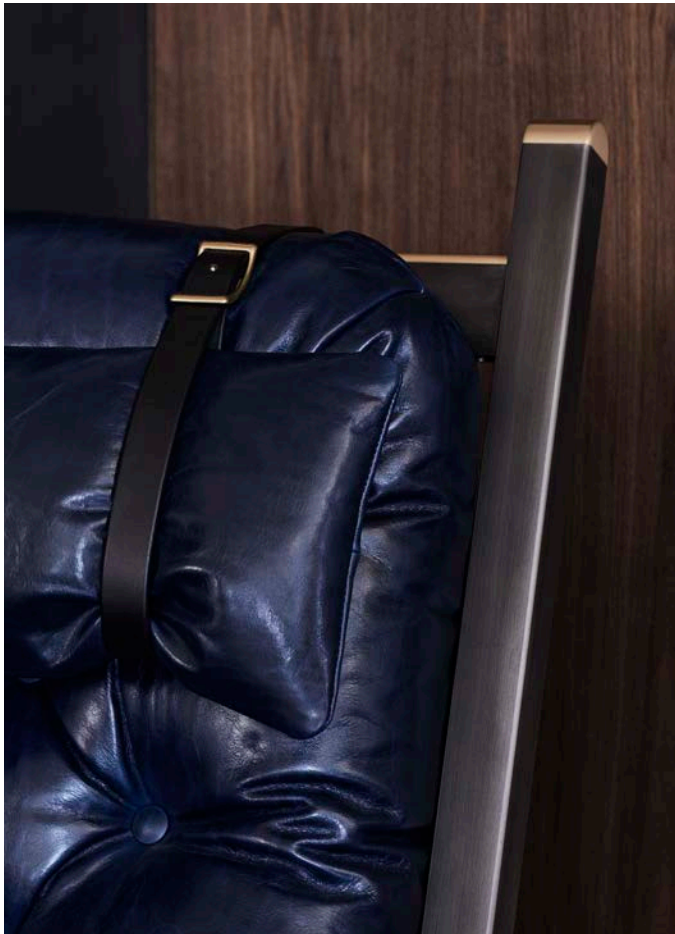

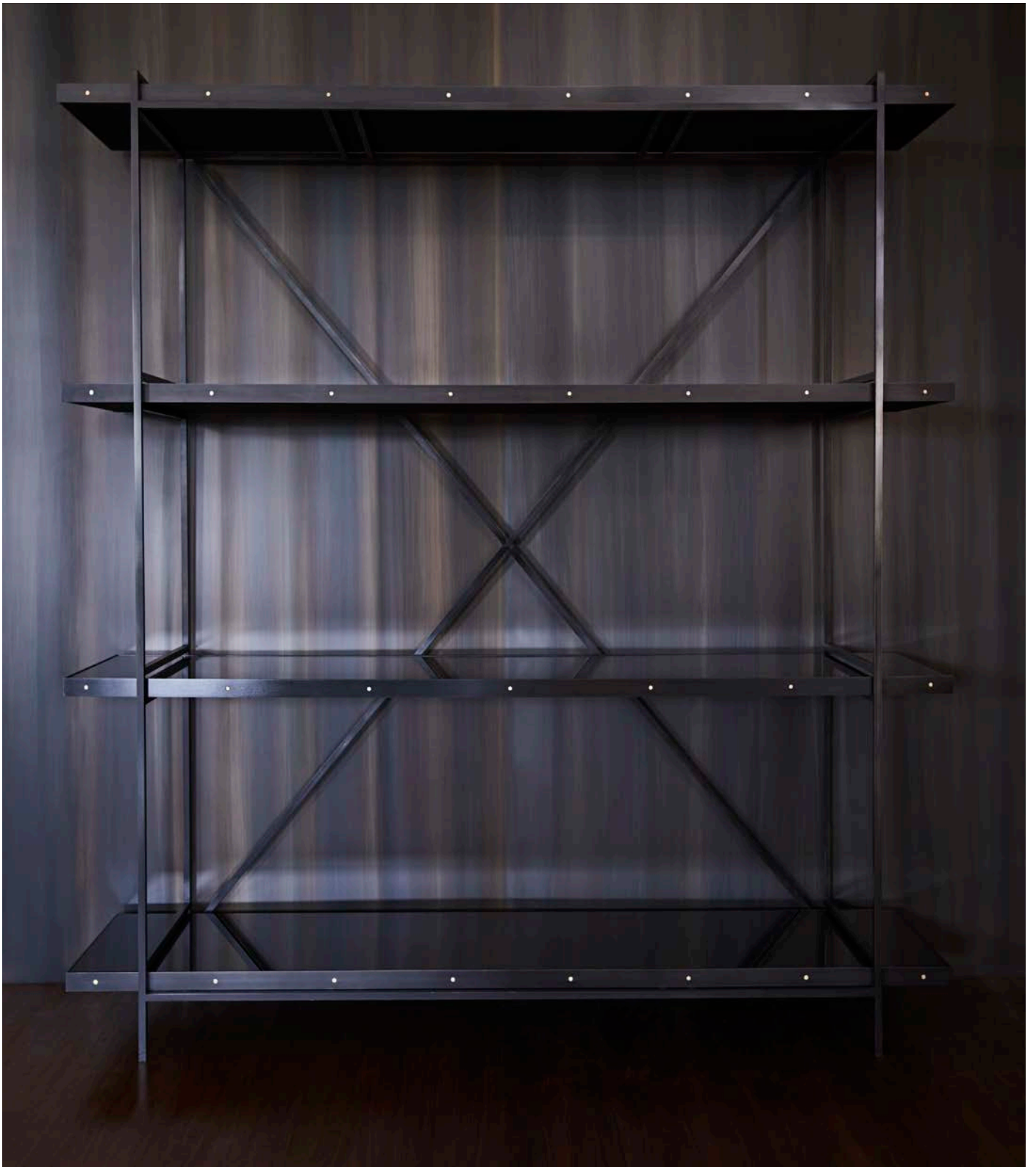

JOHN POMP

OBSIDIAN ÉTAGÈRE

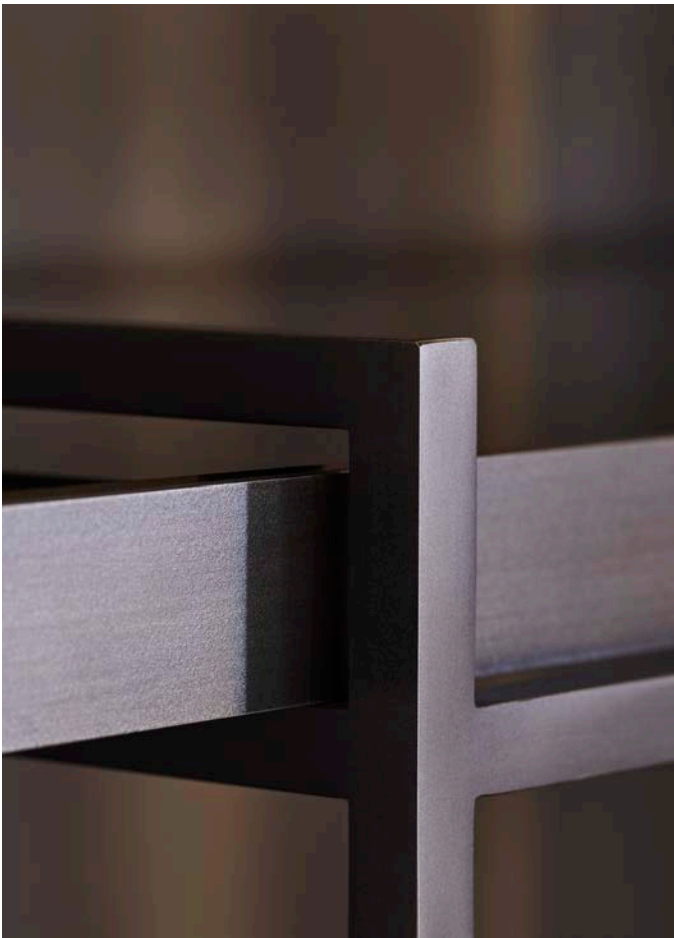

OBSIDIAN ÉTAGÈRE

MODEL NO: JPSOE-01

Open-style shelving unit with brass embellishments and four floating obsidian black glass shelves

AS SHOWN (IN PHOTO)

Metal - frame: light oil rubbed blackened steel
edge banding: light oil rubbed blackened steel

DIMENSIONS

Overall - 60"L x 16.5"D x 66"H

AVAILABLE FINISHES

Frame - oil rubbed blackened steel or light oil rubbed blackened steel

Edge banding - oil rubbed blackened steel, light oil rubbed blackened steel or satin brass

Glass - obsidian black glass

ADDITIONAL NOTES

Lead time is 8-10 weeks. Custom sizing available upon request.

Includes studio mark.

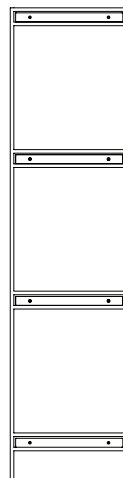
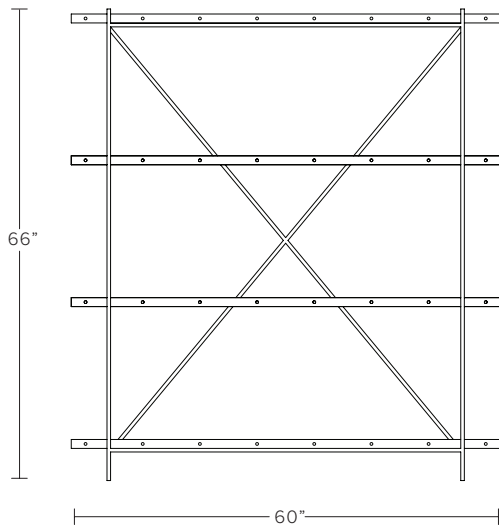



©2020 JOHN POMP STUDIOS



JOHN POMP

DROP STRAP RIPPLED MIRROR



DROP STRAP RIPPLED MIRROR

MODEL NO: JPDSRM-01

Hand-blown, silvered glass mirror suspended in circular metal frame with black hand-stitched leather strap, brass screw detail and metal mounting puck

AS SHOWN (IN PHOTO)

Glass - silvered mirror
Metal - oil rubbed blackened steel

DIMENSIONS

Overall - approximately 34"H (including strap)
Mirror frame - approximately 22" diameter x 1.5"D
Mounting puck - 2" diameter

Glass dimensions may vary slightly due to handmade process

AVAILABLE FINISHES

Mirror - hand-blown, silvered glass mirror or standard plate glass mirror
Metal - oil rubbed blackened steel or light oil rubbed blackened steel
Leather - black, hand-stitched leather strap

ADDITIONAL NOTES

Lead time is 10-12 weeks.

Includes studio mark.

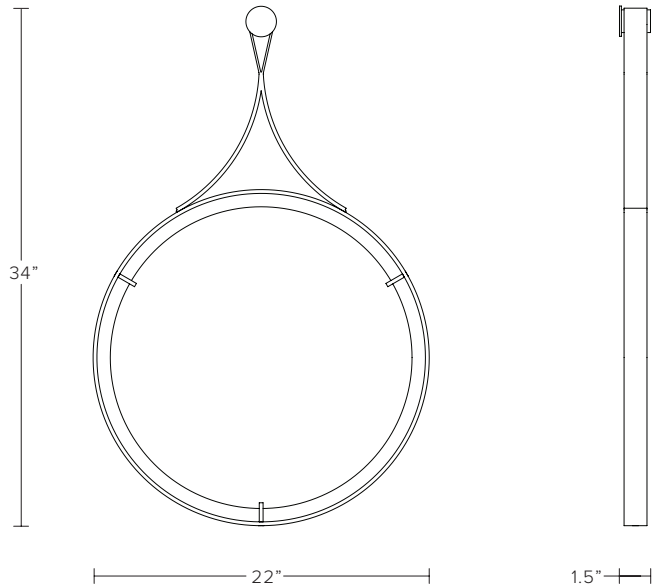



JOHN POMP

STRAIGHT STRAP RIPPLED MIRROR



STRAIGHT STRAP RIPPLED MIRROR

MODEL NO: JPSSRM-01

Hand-blown, silvered glass mirror suspended in circular metal frame with black hand-stitched leather strap, brass screw detail and metal mounting puck

AS SHOWN (IN PHOTO)

Glass - silvered mirror
Metal - oil rubbed blackened steel

DIMENSIONS

Overall - approximately 34"H (including strap)
Mirror frame - approximately 22" diameter x 1.5"D
Mounting puck - 2" diameter

Glass dimensions may vary slightly due to handmade process

AVAILABLE FINISHES

Mirror - hand-blown, silvered glass mirror or standard plate glass mirror
Metal - oil rubbed blackened steel or light oil rubbed blackened steel
Leather - black, hand-stitched leather strap

ADDITIONAL NOTES

Lead time is 10-12 weeks.
Includes studio mark.

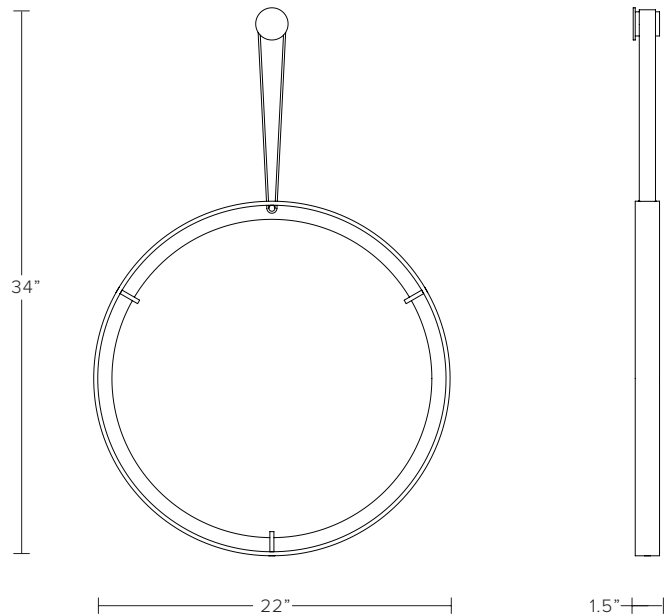

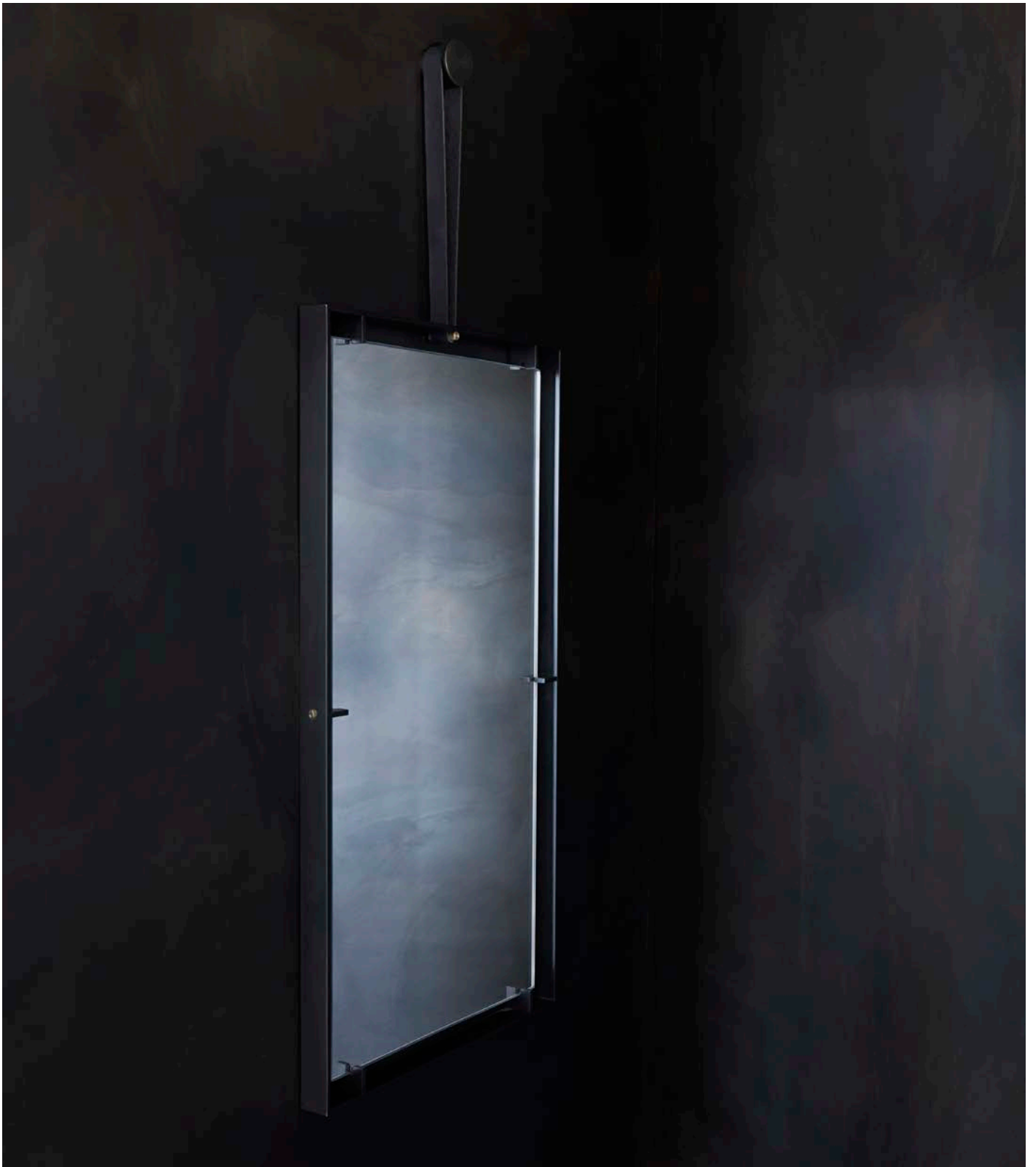

JOHN POMP

FAIRMOUNT MIRROR



FAIRMOUNT MIRROR

MODEL NO: JPSFMM-01

Plate glass mirror suspended in rectangular metal frame with brass screw detail and metal mounting puck

AS SHOWN (IN PHOTO)

Metal - oil rubbed blackened steel

DIMENSIONS

Overall - approximately 45.5"H (including strap) x 17"W x 1.5"D
Mounting puck - 2" diameter

AVAILABLE FINISHES

Mirror - standard plate glass mirror

Metal - oil rubbed blackened steel or light oil rubbed blackened steel

Leather - black, hand-stitched leather strap

ADDITIONAL NOTES

Lead time is 8-10 weeks.

Includes studio mark and craftsperson signature.

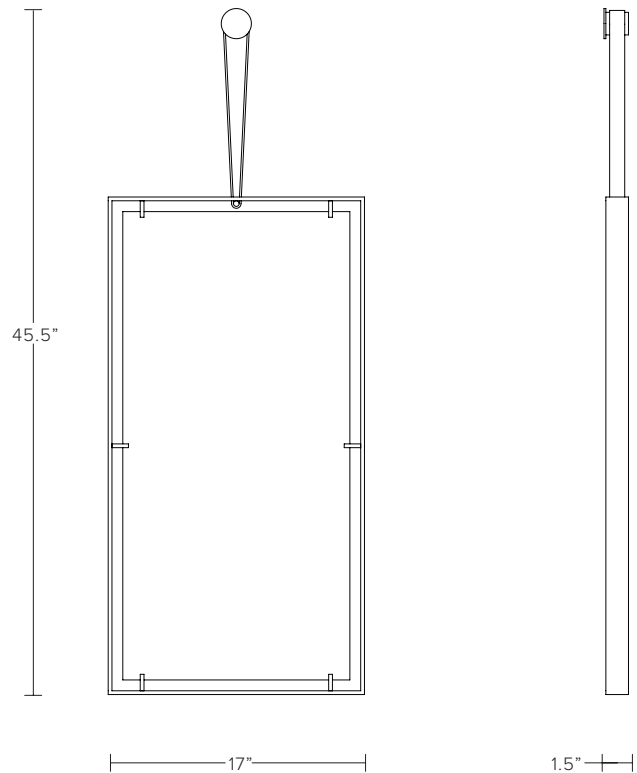

Available Glass Crystal Colors:



CLEAR
(STANDARD)
Transparent



CLEAR WITH IRIDESCENCE
(STANDARD)
Transparent

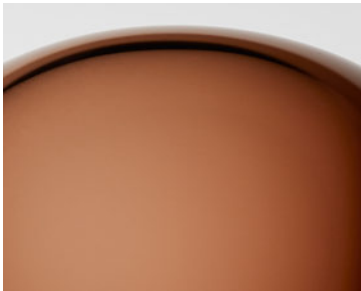

TOPAZ
Transparent



SEPIA
Transparent

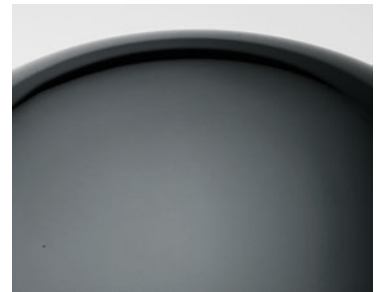

SMOKE
Transparent

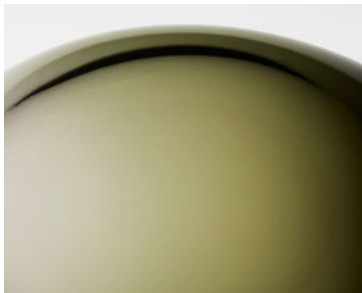

OLIVINE
Transparent



OPALINE
Opaque



GOLD LEAF
Transparent

Available Metal Finishes:



OIL RUBBED
BLACKENED STEEL
(STANDARD)

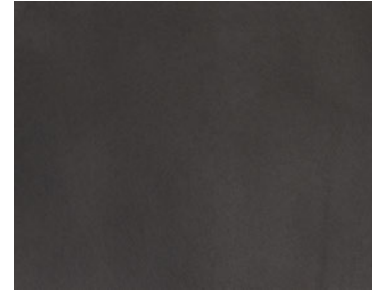

LIGHT OIL RUBBED
BLACKENED STEEL
(STANDARD)

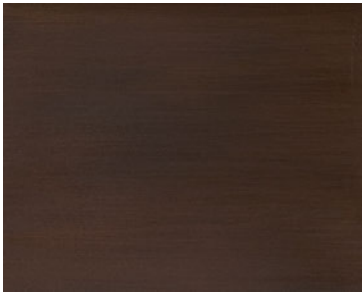

OIL RUBBED BRONZE



SATIN BRASS



SATIN CHROME



SATIN NICKEL

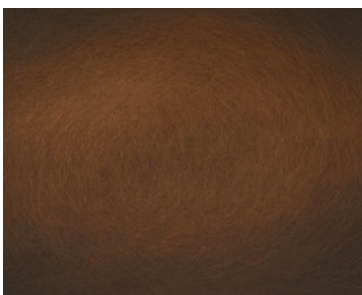

OXIDIZED BRASS

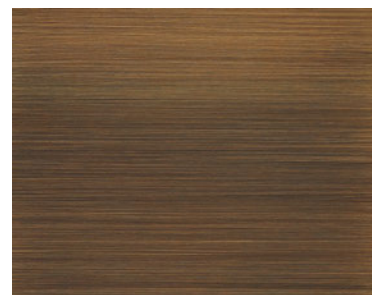

ANTIQUÉ BRASS

Available Glass Crystal Colors:



SOFT ETCHED
CRYSTAL CLEAR
(STANDARD)



SOFT ETCHED
QUARTZ
(STANDARD)

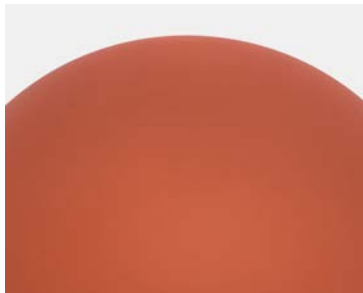

SOFT ETCHED
GARNET



SOFT ETCHED
EMERALD
(MOON ORCHID COLLECTION)

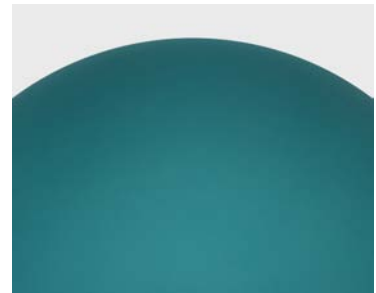

SOFT ETCHED
EMERALD
(BUDDING COLLECTION)



CLEAR CRYSTAL
(TIDAL COLLECTION)



GARNET
(TIDAL COLLECTION)



EMERALD
(TIDAL COLLECTION)



SMOKE
(TIDAL COLLECTION)

Available Metal Finishes:



SATIN BRASS
(STANDARD)



SATIN COPPER



SATIN SILVER



BRUSHED BRASS



BRUSHED SILVER



BRUSHED COPPER

TERMS AND CONDITIONS

TERMS

All John Pomp furniture and lighting is made to order. A deposit of 50% of sale price is required before work will commence. Lead time for production is 8-12 weeks (10-14 for non-standard finishes). Lead time commences at time of shop drawing approval. Shipping time is additional. Full payment, including state or local tax if applicable, crating, handling, storage and insurance (if applicable), shall be made by Customer and received by John Pomp before delivery or shipment to Customer. Rush orders will be assessed with an additional rush fee and expedited shipping fee.

PRICES

All prices are to the trade, freight on board (F.O.B.) Philadelphia, PA. Prices do not include: shipping charges, storage, local delivery, cartoning, crating, packing, sales tax, or uncrating. Prices are in U. S. Dollars.

ORDERING PROCEDURE

All orders must be in writing on order form, with name, purchase order number and full description of desired product included on your purchase order. Deposit check of 50% of sale price must accompany your order and be mailed to our office:

John Pomp

2135 E. Westmoreland Street

Philadelphia, PA 19134

Any alterations or deviation from the specifications involving extra costs will be executed only upon written orders and subject to additional charges and lead time. All pertinent information (checklists, drawings for reference, etc.) is required on orders before production can begin. Shop drawing approval process may affect lead time, if applicable. Shop drawings submitted for edits, comments or approval must be reviewed and sent back to the studio within 5 business days or less from receipt of initial drawings. Production commences once drawing is approved. Approved drawings must be signed, dated and sent back to John Pomp. Once final invoice is paid in full, a signed and dated release confirmation must be sent to John Pomp either via fax, email or certified mail. Fixtures are not adjustable on site.

Lead times will vary by product, the availability of materials and the current production schedule. All quoted completion dates are approximate and cannot be guaranteed until production commences. Rush fees can be assessed prior to placing an order and will be determined based off current production schedule.

Due to limited space in our studio, all orders must be shipped upon completion and final payment. Items not picked up within 20 days of completion will be subject to storage and handling fees. Minimum storage fees of \$250 per month, per item, will be added to your final invoice. No order will be released until storage fees have been paid.

Smaller items will ship via UPS, larger items will ship via freight. If white glove or expedited services are preferred, please specify prior to final invoicing. Delivery dates are approximate and John Pomp will not be responsible for any delay or failure to perform due to circumstances beyond our control. Standard transit for freight is 12-14 business days. In all cases, it is the responsibility of the purchaser to determine if the size of the completed product can be accepted through entry doors. John Pomp does not accept responsibility or liability where on-site conditions and limitations prevent final delivery of items.

Our shipping and handling quotes do not include import duty and VAT. If International crate is required for final destination, it must be clearly indicated on the purchase order.

DESIGNS / DIMENSIONS

All designs are the property of John Pomp. We reserve the exclusive right to produce these designs. Design details are subject to change without notice. All dimensions are approximate. Variations and imperfections are a regular occurrence with the glassblowing process and are integral to achieve the organic quality of our aesthetic.

John Pomp, or a member of John Pomp will be permitted to photograph the installed fixture upon completion of the project.

LUMENAIRES

John Pomp operates as a UL Certified shop and all standard components used in our fixtures have been fabricated in accordance with UL regulations. UL listing will be automatically included for fixtures that meet UL regulations at no additional cost. UL listing information can be found in the John Pomp catalog.

CARE AND MAINTENANCE

Wear nitrile gloves when handling all components of fixture, especially during installation. We recommend using denatured alcohol on all glass components. Cleaning the metal components depends on which finish your piece was made with. Satin chrome, satin nickel, satin brass, oil rubbed blackened steel, light oil rubbed blackened steel, oxidized brass and antique brass finishes can be cleaned using diluted Simple Green solution. DO NOT use acetone or mineral spirits to clean the metal components. Wires can be cleaned with denatured alcohol or your standard glass cleaner. Please refer to care & maintenance and lightbulb resource guide supplied in your shipment for more information regarding care of your product and replacement bulbs.

CHANGES / CANCELLATIONS

Changes in orders are subject to prior written approval by John Pomp. Changes may affect the price and cause production/shipping delays. Cancellations accepted after production begins may forfeit deposit.

RETURNS

We do not accept returns unless the order has arrived damaged. If there are circumstances that require us to accept a return, please note that this will be subject to a 25% restocking fee and the item must be in resalable condition. No returns will be accepted without prior written consent of John Pomp. Authorized returns must be shipped in accordance with shipping instructions issued by John Pomp. Unauthorized returns will be refused. If a rewire of a fixture is required, the original purchase order name/number must be referenced and a quote will be provided. The client will be responsible for repacking and returning the fixture. John Pomp is not responsible for any damage that may have occurred to the fixture upon original installation, de-installation, packing or return shipping. Therefore, once the fixture is received, John Pomp will notify the showroom and/or client of damage as well as any initial cost for touch-up or repair.

FORCE MAJEURE

John Pomp is not liable for delays in shipping or failure to perform due to labor dispute, earthquake, acts of God, compliance with government regulations, or any other cause beyond our control.

TERMS AND CONDITIONS (cont'd)

CLAIMS

All orders are carefully inspected prior to shipment. Our products are packed to exceed UPS and freight shipping requirements and are packed free from defects. When the freight company or delivery service accepts your order the merchandise belongs to you. Purchases must be carefully inspected promptly upon delivery (within 7 business days). If there is any damage, you must describe the extent of damage on the delivery receipt, including photos of damage. All claims must be made in writing and delivered to the freight carrier and John Pomp within 10 days of receiving. Keep all packing materials included in original shipment and repack items the same way they came to return fixture.

WARRANTY

John Pomp products are warranted against defective workmanship and materials for up to one (1) year from date of delivery. This warranty does not extend to customer-supplied materials. During the warranty period, John Pomp will, at its discretion, repair or replace defective merchandise free of charge. This warranty does not extend to damage resulting from shipping, faulty installation, accident, misuse, tampering, alteration, neglect or abuse, nor does it apply to unauthorized repairs. Natural imperfections, minor differences in color density of glass and variegation in metal patinas are inherent qualities of the materials and finishes used in hand made lighting fixtures and are not to be considered defects, therefore are not covered under warranty. In no event shall liability exceed the original purchase price of the lighting fixture(s). John Pomp is committed to producing the highest quality glass and metal products that are thoughtfully and carefully engineered.



JOHN POMP

CARE & MAINTENANCE GUIDE

ALWAYS WEAR NITRILE GLOVES WHEN HANDLING OR APPLYING ANY PRODUCTS TO FURNITURE TO AVOID FINGERPRINTS AND CONTACT WITH SKIN

exposure

- DO NOT STORE HANDBLOWN GLASS NEAR STEEL OR OTHER GLASS ITEMS WHICH CAN SCRATCH OR DAMAGE THE SURFACE.
- KEEP PIECES INSIDE WHERE TEMPERATURES ARE REGULATED. THE GLASS CAN EXPERIENCE THERMAL SHOCK AND BREAK IF YOU EXPOSE IT TO EXTREME TEMPERATURE VARIATIONS.
- WIRE AND HARDWARE COMPONENTS CAN BE CLEANED WITH DENATURED ALCOHOL OR YOUR STANDARD GLASS CLEANER.

glass

- MIRROR FACE CAN BE CLEANED WITH A MICRO FIBER CLOTH AND WARM WATER OR WINDEX. THE BACK AND SIDE OF HAND-BLOWN MIRROR SHOULD BE LEFT UNTOUCHED BY WATER AND SOLVENTS. IF NEEDED CLEAN WITH HAND-HELD DUSTER.
- RONDELLE GLASS CAN BE CLEANED WITH WARM WATER AND WIPED WITH A SOFT CLOTH AFTER CLEANING TO AVOID WATER SPOTS.
- WITH THE EXCEPTION OF GOLD LEAF PRODUCTS, HAND-WASH ALL HANDBLOWN GLASS ITEMS WITH DENATURED ALCOHOL, OR WARM WATER.
- WIPE THE GLASS INSIDE AND OUT WITH A SOFT CLOTH AFTER CLEANING TO AVOID WATER SPOTS.
- GOLD LEAF GLASS MAY BE CLEANED WITH A SOFT CLOTH AND AN AMMONIA-FREE GLASS CLEANER.
- REMOVE WATER SPOTS WITH A MIXTURE OF WARM WATER AND VINEGAR.

metal

- DO NOT USE ACETONE, SOLVENTS, MINERAL SPIRITS OR HARSH CHEMICALS.
- METAL FINISHES CAN BE CLEANED USING A SOFT CLOTH AND DILUTED SIMPLE GREEN SOLUTION.

wood

- WOOD COMPONENTS CAN BE CLEANED USING A SOFT DAMP CLOTH AND DILUTED SIMPLE GREEN IN LOCALIZED AREAS.
- TO BRIGHTEN THE APPEARANCE OF THE WOOD, WE RECOMMEND A ROUTINE APPLICATION OF HOWARD FEED-N-WAX.
- ALWAYS USE A CLEAN SOFT CLOTH WHEN APPLYING ANY CONDITIONER.

leather

- LEATHER COMPONENTS CAN BE CLEANED WITH A CLEAN SOFT CLOTH AND A GOOD QUALITY LEATHER CONDITIONER. DO NOT USE A LEATHER CONDITIONER WITH ANY HARSH SOLVENTS. WE RECOMMEND CHAMBERLAIN'S LEATHER MILK NUMBER 1. BUFF IN CONDITIONER WITH A CLEAN SOFT CLOTH.



JOHN POMP

LIGHTBULB RESOURCE GUIDE

FOR NEW OR REPLACEMENT LIGHT BULBS, PLEASE REFER TO THE GUIDE BELOW FOR YOUR SPECIFIC FIXTURE AND WATTAGE

INCANDESCENT

ROCK EDGE CHANDELIER	30" OD	60W	ITEM CODE: 704160 (BULBRITE)
	36" OD	60W	ITEM CODE: S2422 (SATCO)
	42" OD	75W	ITEM CODE: 705175 (BULBRITE)
	48" OD		
OSTREA / JULES CHANDELIER		60W	ITEM CODE: 136019 (BULBRITE)
CALLA MOBILE / CHANDELIER / PENDANT / INFINITY CHANDELIER		6W	ITEM CODE: 708106 (BULBRITE)
INFINITY CLUSTER / SCONCE / CLEAR BAND SCONCE / OPTIC MARBLE CLUSTER / SCONCE / SPUN THREAD CLUSTER / SCONCE		15W	ITEM CODE: IN-706115 (BULBRITE)
INFINITY PENDANT / CLEAR BAND PENDANT (WIDE / SPHERE)		40W	ITEM CODE: IN-134019 (BULBRITE)
		60W	ITEM CODE: 136019 (BULBRITE)
CLEAR BAND PENDANT (LONG) / FLOOR LAMP		30W	ITEM CODE: 133009 (BULBRITE)
BUDDING PENDANT		40W	ITEM CODE: S3828 (SATCO)
BUDDING CHANDELIER / SCONCE / TIDAL CHANDELIER / MOON ORCHID - CREST / CASCADING / SCONCE		25W	ITEM CODE: 391025 (BULBRITE)
ECLIPSE PENDANT		40W	ITEM CODE: 393004 (BULBRITE)
		25W	ITEM CODE: 707211 (BULBRITE)
LUMENARIUMS (HIGH & LOW)		30W	ITEM CODE: 133009 (BULBRITE)
		40W	ITEM CODE: 705140 (BULBRITE)

LED ALTERNATIVES

ROCK EDGE CHANDELIER	30" OD	2W	ITEM CODE: 776608 (BULBRITE)
	36" OD		
	42" OD	4W	ITEM CODE: 776507 (BULBRITE)
	48" OD		
OSTREA / JULES CHANDELIER / INFINITY PENDANT / CLEAR BAND PENDANT (WIDE / SPHERE)		5W	ITEM CODE: 776801 (BULBRITE)
CLEAR BAND PENDANT (LONG) / FLOOR LAMP		4W	ITEM CODE: 776907 (BULBRITE)
INFINITY CLUSTER / SCONCE / OPTIC MARBLE CLUSTER / SCONCE / SPUN THREAD CLUSTER / SCONCE		2.5W	ITEM CODE: 776904 (BULBRITE)
INFINITY CHANDELIER / CLEAR BAND SCONCE / MOON ORCHID SCONCE		2W	ITEM CODE: T22D-X2DF-E12 (SUPERBRIGHTLEDS)
BUDDING CHANDELIER / SCONCE		4W	ITEM CODE: OPR-G45-4W-2700K-F (OPALRAY)
BUDDING PENDANT		9W	ITEM CODE: 28395 (CREATIVE GREEN)
MOON ORCHID - CREST / CASCADING / CREST SCONCE / TIDAL CHANDELIER		4W	ITEM CODE: 1002919757 (ECOSMART)
ECLIPSE PENDANT		4W	ITEM CODE: 1002917889 (ECOSMART)